

# Sunday School Calendar 2023-2024 School Year

First Semester <i>September - December 2023</i>		Second Semester <i>January - May 2024</i>	
Date	Lesson	Date	Lesson
		Jan. 7	Jesus Heals the Paralytic
		Jan. 14	The Daughter of Jairus
Sept. 10	Zacharias	Jan. 21	The Centurion's Servant
Sept. 17	The Birth of Christ Announced	Jan. 28	The Young Man from Nain
Sept. 24	The Birth of Christ	Feb. 4	The Sower and the Seed
Oct. 1	The Wise Men / Flight to Egypt	Feb. 11	The Feeding of the 5000
Oct. 8	The Boy Jesus in the Temple	Feb. 18	Jesus Walks on the Water
Oct. 15	John the Baptizer	Feb. 25	The Woman of Canaan
Oct. 22	The Temptation of Jesus	March 3	The Transfiguration
Oct. 29	Jesus' First Miracle	March 10	The Unforgiving Servant
Nov. 5	The First Disciples	March 17	The Pharisee and the Publican
Nov. 12	Jesus and Nicodemus	March 24	Palm Sunday Breakfast
Nov. 19	Jesus and the Samaritan Woman	March 31	Easter movie
Nov. 26	The Pool of Bethesda	Apr. 7	Jesus and the Little Children
Dec. 3	Christmas Eve Practice	Apr. 14	The Good Samaritan
Dec. 10	Christmas Eve Practice	Apr. 21	Mary and Martha
Dec. 17	Christmas Eve Practice	Apr. 28	The Prodigal Son
Dec. 22	Christmas Eve Practice	May 5	The Rich Man and Poor Lazarus
<b>Dec. 24</b>	<b>Christmas Eve</b>	May 12	The Raising of Lazarus
<b>Dec. 25</b>	<b>Christmas Day</b>	May 19	The Parable of the Ten Virgins
Dec. 31	<i>(No Sunday School)</i>		
<b>2023 Total Lessons: 12</b>		<b>2024 Total Lessons: 18</b>	

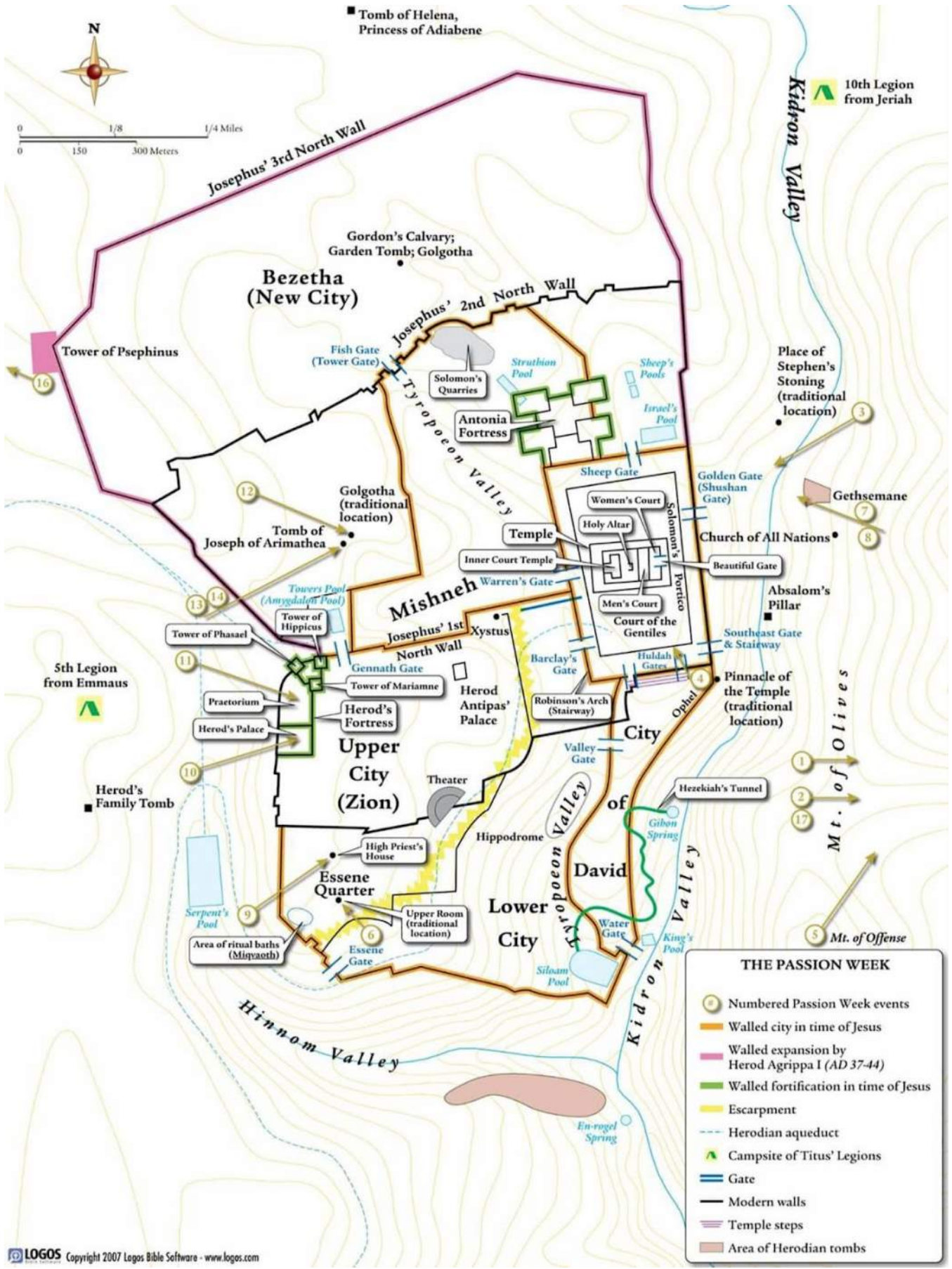

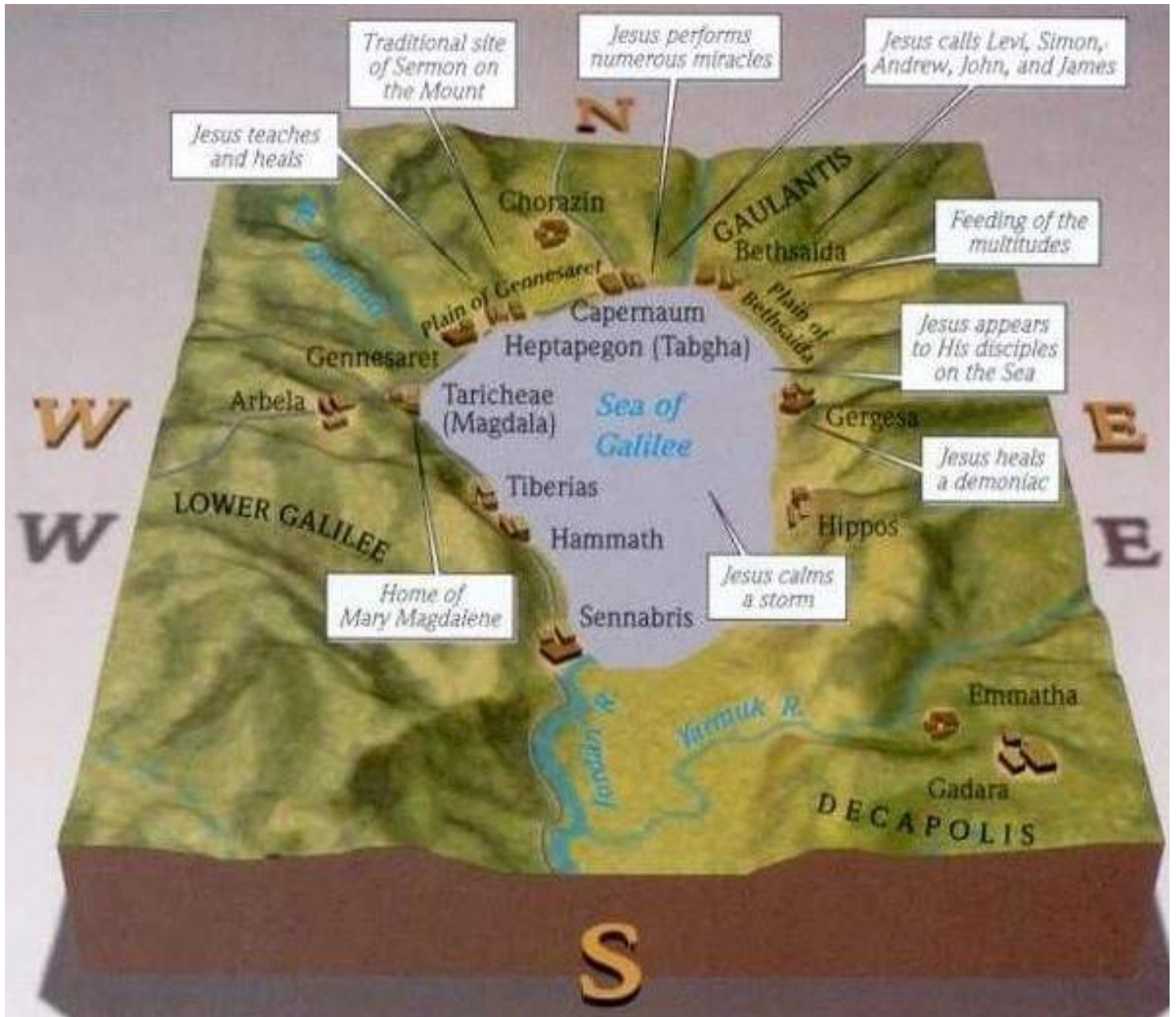

## Zacharias and the Birth of John

Luke 1:5-25, 57-80

What sorts of things do people promise to one another?

Why do we sometimes add the words "I promise" to what we say?

Are people's promises ever broken?

### Prayer

Dear Heavenly Father, Your promises are the most important truths we have. You promised and sent Your Son who took our sins away. You have promised to be with us always. You have promised to take us to heaven. Help us remember that all Your promises are sure! Amen.



### The Story ( Luke 1:5-25; 57-80)

There was in the days of Herod, the king of Judea, a certain priest named Zacharias, of the division of Abijah. His wife was of the daughters of Aaron, and her name was Elizabeth. (6) And they were both righteous before God, walking in all the commandments and ordinances of the Lord blameless. (7) But they had no child, because Elizabeth was barren, and they were both well advanced in years.

(8) So it was, that while he was serving as priest before God in the order of his division, (9) according to the custom of the priesthood, his lot fell to burn incense when he went into the temple of the Lord. (10) And the whole multitude of the people was praying outside at the hour of incense.

(11) Then an angel of the Lord appeared to him, standing on the right side of the altar of incense. (12) And when Zacharias saw him, he was troubled, and fear fell upon him. (13) But the angel said to him, "Do not be afraid, Zacharias, for your prayer is heard; and your wife Elizabeth will bear you a son, and you shall call his name John. (14) And you will have joy and gladness, and many will rejoice at his birth. (15) For he will be great in the sight of the Lord, and shall drink neither wine nor strong drink. He will also be filled with the Holy Spirit, even from his mother's womb. (16) And he will turn many of the children of Israel to the Lord their God. (17) He will also go before Him in the spirit and power of Elijah, 'to turn



the hearts of the fathers to the children,' and the disobedient to the wisdom of the just, to make ready a people prepared for the Lord."

(18) And Zacharias said to the angel, "How shall I know this? For I am an old man, and my wife is well advanced in years."

(19) And the angel answered and said to him, "I am Gabriel, who stands in the presence of God, and was sent to speak to you and bring you these glad tidings. (20) But behold, you will be mute and not able to speak until the day these things take place, because you did not believe my words which will be fulfilled in their own time."

(21) And the people waited for Zacharias, and marveled that he lingered so long in the temple. (22) But when he came out, he could not speak to them, for he beckoned to them and remained speechless.

(23) So it was, as soon as the days of his service were completed, that he departed to his own house. (24) Now after those days his wife Elizabeth conceived; and she hid herself five months, saying, (25) "This the Lord hath dealt with me, in the days when He looked on me to take away my reproach among people."

(57) Now Elizabeth's full time came for her to be delivered, and she brought forth a son. (58) When her neighbors and relatives heard how the Lord had shown great mercy to her, they rejoiced with her.

(59) So it was, on the eighth day, that they came to circumcise the child; and they would have called him by the name of his father, Zacharias. (60) His mother answered and said, "No; he shall be called John"

(61) But they said to her, "There is no one among your relatives who is called by this name." (62) So they made signs to his father - what he would have him called. (63) And he asked for a writing tablet, and wrote, saying, "His name is John." So they all marveled.

(64) Immediately his mouth was

opened and his tongue loosed, and he spoke, praising God.

(65) Then fear came on all who dwelt around them; and all these sayings were discussed throughout all the hill country of Judea. (66) And all those who heard them kept them in their hearts, saying "What kind of child will this be?" And the hand of the Lord was with him.

(67) Now his father Zacharias was filled with the Holy Spirit, and prophesied, saying: (68) "Blessed is the Lord God of Israel, For He has visited and redeemed His people, (69) And has raised up a horn of salvation for us In the house of His servant David, (70) As He spoke by the mouth of His holy prophets, Who have been since the world began, (71) That we should be saved from our enemies And from the hand of all who hate us, (72) To perform the mercy promised to our fathers And to remember His holy covenant, (73) The oath which He swore to our father Abraham: (74) To grant that we, Being delivered from the hand of our enemies, Might serve Him without fear, (75) In holiness and righteousness before Him all the days of our life.

(76) "And you, child, will be called the prophet of the Highest; For you will go before the face of the Lord to prepare His ways, (77) To give knowledge of salvation to His people By the remission of their sins, (78) Through the tender mercy of our God, With which the Dayspring from on high has visited us; (79) To give light to those who sit in darkness and the shadow of death, To guide our feet into the way of peace."

(80) So the child grew and became strong in spirit, and was in the deserts till the day of his manifestation to Israel.

**What the Story Tells Us** - Fill in the blanks with the best answer from the lesson.

1. \_\_\_\_\_ was a priest.
2. \_\_\_\_\_ was his wife.
3. Gabriel said that God promised to give Zacharias a \_\_\_\_\_.
4. Because Zacharias doubted, he was not able to \_\_\_\_\_.
5. When the time came to name the baby, Zacharias wrote, " His \_\_\_\_\_ is \_\_\_\_\_."
6. John would point people to \_\_\_\_\_.

---

**Outer Aim**

**God sends John as a messenger to prepare for Jesus' coming.**

---

**What God Tells Us** - Mark each as (T) rue or (F) alse.

1. \_\_\_\_\_ Zacharias and Elizabeth prayed for a son.
2. \_\_\_\_\_ God would not give them what they asked because Zacharias doubted.
3. \_\_\_\_\_ God kept His promise.
4. \_\_\_\_\_ God sent John to be a priest in the temple.
5. \_\_\_\_\_ Elizabeth named the baby after his father.
6. \_\_\_\_\_ God's promises are still sure today.

---

**Inner Aim** God keeps His promises.

---

## Passages

"For God so loved the world that He gave His only begotten Son, that whoever believes in Him should not perish but have everlasting life." John 3:16

Jesus said, "Lo, I am with you always, even to the end of the age." Amen. Matthew 28:20

"Have I not commanded you? Be strong and of good courage; do not be afraid, nor be dismayed, for the LORD your God is with you wherever you go." Joshua 1:9

Now, faith is the substance of things hoped for, the evidence of things not seen.  
Hebrews 11:1

## Hymn - TLH 428 v. 1-4

I am trusting Thee, Lord Jesus,  
Trusting only Thee;  
Trusting Thee for full salvation,  
Great and free.

I am trusting Thee for cleansing  
In the crimson flood;  
Trusting Thee to make me holy  
By Thy blood.

I am trusting Thee for pardon;  
At Thy feet I bow,  
For Thy grace and tender mercy  
Trusting now.

I am trusting Thee to guide me;  
Thou alone shalt lead,  
Ev'ry day and hour supplying  
All my need.

Hymn 428 was written hundreds of years after Zacharias' and Elizabeth's time. Explain whether or not this hymn could apply to them.

**Your Turn** - Make three columns on a sheet of paper. In the first column, list as many of God's promises as you can. Next to each one, list who first received the promise. In the third column, show which promises apply to you.

## Prayer

Dear Father in heaven,

We have learned that You keep all Your promises to us. When our reason would make us doubt Your Word and our patience wears thin, overcome our doubt and strengthen our faith to believe Your promises will be fulfilled according to Your wise plans. Send Your Holy Spirit on us that we may be bold in believing Your promises of forgiveness, of life and salvation in Jesus and so reach the home You have promised to all who believe in Jesus. Amen.

## Announcing A Miracle Child

Luke 1:26-56; Matthew 1:19-25

Look at the picture carefully!  
Is this picture possible?  
Is it impossible?  
Is anything impossible?

### Prayer

Dear Lord,

You alone are capable of the impossible. Help me to see the miracle of our Savior's birth through the eyes of faith. With You, all things are truly possible. Amen.

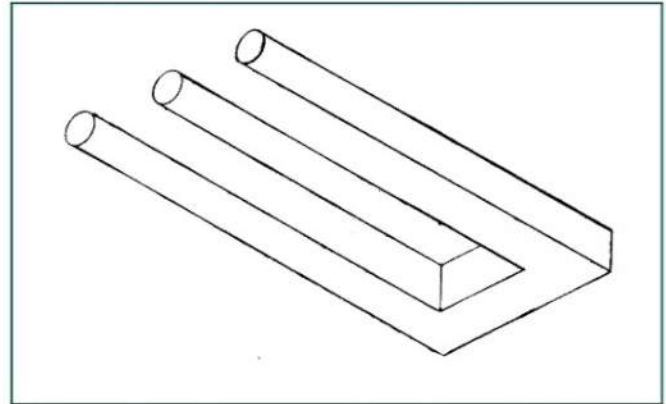

### The Story - Luke 1:26-56

Now in the sixth month the angel Gabriel was sent by God to a city of Galilee named Nazareth, (27) to a virgin betrothed to a man whose name was Joseph, of the house of David. The virgin's name was Mary. (28) And having come in, the angel said to her, "Rejoice, highly favored one, the Lord is with you; blessed are you among women!"

(29) But when she saw him, she was troubled at his saying, and considered what manner of greeting this was. (30) Then the angel said to her, "Do not be afraid, Mary, for you have found favor with God. (31) And behold, you will conceive in your womb and bring forth a Son, and shall call His name JESUS.

(32) He will be great, and will be called the Son of the Highest; and the Lord God will give Him the throne of His father David. (33) And He will reign over the house of Jacob forever, and of His kingdom there will be no end."

(34) Then Mary said to the angel, "How can this be, since I do not know a man?"

(35) And the angel answered and said to her, "The Holy Spirit will come upon you, and the power of the Highest will overshadow you; therefore, also, that Holy One who is to be born of you will be called the Son of God.

(36) Now indeed, Elizabeth your relative has also conceived a son in her old age; and this is now the sixth month for her who was called barren. (37) For





with God nothing shall be impossible.”

(38) Then Mary said, “Behold the maidservant of the Lord! Let it be to me according to your word.” And the angel departed from her.

(39) Now Mary arose in those days and went into the hill country with haste, to a city of Judah, (40) and entered the house of Zacharias and greeted Elizabeth.

(41) And it happened, when Elizabeth heard the greeting of Mary, that the babe leaped in her womb; and Elizabeth was filled with the Holy Spirit. (42) Then she spoke out with a loud voice and said, “Blessed are you among women, and blessed is the fruit of your womb! (43) But why is this granted to me, that the mother of my Lord should come to me? (44) For indeed, as soon as the voice of your greeting sounded in my ears, the babe leaped in my womb for joy. (45) Blessed is she who believed, for there will be a fulfillment of those things which were told her from the Lord.”

(46) And Mary said: “My soul magnifies the Lord, (47) and my spirit has rejoiced in God my Savior. (48) For He has regarded the lowly state of His maidservant; For behold, henceforth all generations will call me blessed. (49) For He who is mighty has done great things for me, And holy is His name. (50) And His mercy is on those who fear Him From generation to generation. (51) He has shown strength with His arm; He has scattered the proud in the imagination of their hearts. (52) He has put down the

mighty from their thrones, And exalted the lowly. (53) He has filled the hungry with good things, And the rich He has sent away empty. (54) He has helped His servant Israel, In remembrance of His mercy, (55) As He spoke to our fathers, To Abraham and to his seed forever.”

(56) And Mary remained with her about three months, and returned to her house.

### **Matthew 1:19-25**

Joseph her husband, being a just man, and not wanting to make her a public example, was minded to put her away secretly.

(20) But while he thought about these things, behold, an angel of the Lord appeared to him in a dream, saying, “Joseph, son of David, do not be afraid to take to you Mary your wife, for that which is conceived in her is of the Holy Spirit. (21) And she will bring forth a Son, and you shall call His name JESUS, for He will save His people from their sins.”

(22) So all this was done that it might be fulfilled which was spoken by the Lord through the prophet, saying: (23) “Behold, the virgin shall be with child, and bear a Son, and they shall call His name Immanuel,” which is translated, “God with us.” (24) Then Joseph, being aroused from sleep, did as the angel of the Lord commanded Him and took to him his wife, (25) and did not know her till she had brought forth her firstborn Son. And he called His name JESUS.

---

**Outer Aim - God announces the miracle of Jesus' birth.**

---

**What the Story Tells Us** - Write the correct letter in the blank.

1. Mary was \_\_\_\_\_ to Joseph.
  - a. married
  - b. engaged
  - c. related
2. Gabriel was sent by God to tell Mary she would be the mother of \_\_\_\_\_.
  - a. John
  - b. Joseph
  - c. Jesus
3. Mary wondered how this could be because she didn't have a \_\_\_\_\_.
  - a. husband
  - b. house
  - c. doctor
4. With God, nothing is \_\_\_\_\_.
  - a. impossible
  - b. easy
  - c. finished
5. When Elizabeth saw Mary, her baby \_\_\_\_\_.
  - a. said, "Jesus!"
  - b. was born
  - c. leaped in her womb
6. Mary praised God for \_\_\_\_\_.
  - a. doing great things for her
  - b. scattering the proud and exalting the lowly
  - c. sending the Savior
  - d. all of the above

---

**Inner Aim - Believers show faith in the miracle of Jesus' birth.**

---

**What God Tells Us** - Write "M" after each statement that identifies a miracle.

1. Mary was pregnant with Jesus. \_\_\_\_\_
2. Mary believed the words of Gabriel. \_\_\_\_\_
3. Joseph believed the words of Gabriel. \_\_\_\_\_
4. When Mary saw her, Elizabeth's baby leaped in her womb. \_\_\_\_\_
5. We believe the truth of Jesus' birth. \_\_\_\_\_

## Hymn - TLH 95 v. 1-4

Savior of the nations, come,  
Virgin's Son, make here Thy home!  
Marvel now, O heav'n and earth,  
That the Lord chose such a birth.

Not by human flesh and blood,  
By the Spirit of our God,  
Was the Word of God made flesh —  
Woman's Offspring, pure and fresh.

Wondrous birth! O wondrous Child  
Of the Virgin undefiled!  
Tho' by all the world disowned,  
Still to be in heav'n enthroned.

From the Father forth He came  
And returneth to the same,  
Captive leading death and hell —  
High the song of triumph swell!

## Passages

Matthew 1:21 "And she will bring forth a Son, and you shall call His name JESUS, for He will save His people from their sins."

Luke 1:37 "For with God nothing will be impossible."

Isaiah 7:14 "Therefore the Lord Himself will give you a sign; Behold, the virgin shall conceive and bear a Son, and shall call His name Immanuel."

Galatians 4:4 But when the fullness of the time had come, God sent forth His Son, born of a woman, born under the law.

**Your Turn** - Mary showed her faith in God in the words of her song and in following God's directions for her. List ways we can show our faith. Write a prayer asking God to help us do so.

## Prayer

Dear Father in Heaven,

You teach us today that Jesus is both Your only begotten Son and also a human being born of a virgin Mary. This miracle made Jesus both God and Man, and so our perfect, holy Savior; we know this is a matter of faith. O Lord, strengthen our faith in this and all other mysteries of Scripture, that we may remain Your children now and into eternity. Help us to show our faith with words of praise and deeds of obedience, that blessing may come through us as Your servants. In the name of Jesus, our Savior, we pray. Amen.

## The Birth of Jesus

Luke 2:1-20

What might be inside these gifts?

- Is it something to use, or a keepsake?
- Is it something needed, or just wanted?
- Is it for one person or to be shared?

What other types of gifts are there?

Today we will learn about the best Gift ever.



### Prayer

Dear God,

There are, indeed, many kinds of gifts. We ask that You would be with us today as we consider the very special gift You gave all people through Your Son, Jesus. Amen.

### The Story - Luke 2:1-20

And it came to pass in those days that a decree went out from Caesar Augustus that all the world should be registered. {2} This census first took place while Quirinius was governing Syria.

{3} So all went to be registered, everyone to his own city. {4} Joseph also went up from Galilee, out of the city of Nazareth, into Judea, to the city of David, which is called Bethlehem, because he was of the house and lineage of David, {5} to be registered with Mary, his betrothed wife, who was with child.

{6} So it was, that while they were there, the days were completed for her to be delivered. {7} And she brought

forth her firstborn Son, and wrapped Him in swaddling cloths, and laid Him in a manger, because there was no room for them in the inn.

{8} Now there were in the same country shepherds living out in the fields, keeping watch over their flock by night. {9} And behold, an angel of the Lord stood before them, and the glory of the Lord shone around them, and they were greatly afraid.

{10} Then the angel said to them, "Do not be afraid, for behold, I bring you good tidings of great joy which will be to all people. {11} "For there is born to you this day in the city of David a Savior, who is Christ the Lord. {12} "And this will be the sign to you: You will find a



Babe wrapped in swaddling cloths,  
lying in a manger."

{13} And suddenly there was with  
the angel a multitude of the heavenly  
host praising God and saying: {14}  
"Glory to God in the highest, And on  
earth peace, goodwill toward men!"

{15} So it was, when the angels  
had gone away from them into  
heaven, that the shepherds said to one  
another, "Let us now go to Bethlehem  
and see this thing that has come to  
pass, which the Lord has made known  
to us."

{16} And they came with haste

and found Mary and Joseph, and the  
Babe lying in a manger. {17} Now when  
they had seen Him, they made widely  
known the saying which was told them  
concerning this Child. {18} And all those  
who heard it marveled at those things  
which were told them by the  
shepherds.

{19} But Mary kept all these things  
and pondered them in her heart. {20}  
Then the shepherds returned, glorifying  
and praising God for all the things that  
they had heard and seen, as it was told  
them.

**What the Story Tells Us** - You have been asked to tell some people about the birth of  
Jesus - but you can only use 5 sentences to tell the story. Write here the 5 sentences you  
would use.

1.

2.

3.

4.

5.

---

**Outer Aim - Jesus our Savior is born.**

---

**What God's Word Tells Us** - Speaking of Gifts... Look at the following passages. What are some of the other gifts God has given His people? Highlight or underline the gifts in the passages.

Genesis 1:1 - In the beginning God created the heavens and the earth.

I Corinthians 11:23-26 - For I received from the Lord that which I also delivered to you: that the Lord Jesus on the same night in which He was betrayed took bread; and when He had given thanks, He broke it and said, "Take, eat; this is My body which is broken for you; do this in remembrance of Me." In the same manner He also took the cup after supper, saying, "This cup is the new covenant in My blood. This do, as often as you drink it, in remembrance of Me." For as often as you eat this bread and drink this cup, you proclaim the Lord's death till He comes.

Galatians 4:4-5 - But when the fullness of the time had come, God sent forth His Son, born of a woman, born under the law, to redeem those who were under the law, that we might receive the adoption as sons.

Isaiah 40:8 - The grass withers, the flower fades, but the word of our God stands forever."

Ephesians 4:11-12 - And He Himself gave some to be apostles, some prophets, some evangelists, and some pastors and teachers, for the equipping of the saints for the work of ministry, for the edifying of the body of Christ.

Romans 6:3 - Or do you not know that as many of us as were baptized into Christ Jesus were baptized into His death?

---

**Inner Aim - Jesus, the Promised Savior, is Born!**

---

## Passages

Luke 2:11 - For there is born to you this day in the city of David a Savior, who is Christ the Lord.

Titus 2:11 - For the grace of God that brings salvation has appeared to all men.

Isaiah 9:6 - For unto us a Child is born, Unto us a Son is given; and the government will be upon His shoulder. And His name will be called Wonderful, Counselor, Mighty God, Everlasting Father, Prince of Peace.

**Hymn Study** - Use Hymn #85 "From Heaven Above To Earth I Come" vs. 1-4 to answer the following.

"From heav'n above to earth I come  
To bear good news to ev'ry home;  
Glad tidings of great joy I bring,  
Whereof I now will say and sing:

"This is the Christ, our God and Lord,  
Who in all need shall aid afford;  
He will Himself your Savior be  
From all your sins to set you free.

"To you this night is born a child  
Of Mary, chosen virgin mild;  
This little child, of lowly birth,  
Shall be the joy of all the earth.

"He will on you the gifts bestow  
Prepared by God for all below,  
That in His kingdom, bright and fair,  
You may with us His glory share.

1. Who is speaking in verse 1?
2. Which words of verse 2 describe Jesus' mother?
3. Why would this child be the joy of all the earth?
4. Verse 3 says "who in all need shall aid afford". Can you give some examples from your life of times that Jesus has helped you?
5. How would Jesus set us free from sin? (verse 3)
6. What is the ultimate Christmas gift? (verse 4)

## Prayer

My heart for very joy doth leap,  
My lips no more can silence keep;  
I, too, must sing with joyful tongue  
That sweetest ancient cradle-song:

Glory to God in highest heaven,  
Who unto us His Son hath given!  
While angels sing with pious mirth  
A glad new year to all the earth.  
Amen.

## The Wise Men and Flight to Egypt

Matthew 2:1-23

When people look at the stars they probably think of many different things.

What do you think of?

Many people allow the stars to control their lives. How?

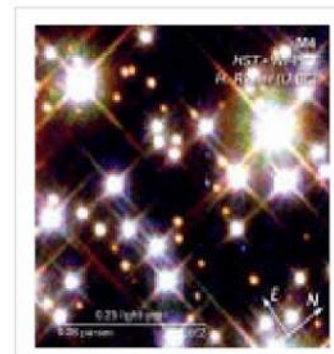

### Prayer

Dear Lord,

The stars are a very beautiful part of Your creation. You placed a special star in the sky to guide the wise men. As we learn about the effects of that star, help us to be filled with awe at the working of Your plan for the salvation of the world. Amen.

### The Story - Matthew 2:1-23

Now after Jesus was born in Bethlehem of Judea in the days of Herod the king, behold, wise men from the East came to Jerusalem, {2} saying, "Where is He who has been born King of the Jews? For we have seen His star in the East and have come to worship Him."

{3} When Herod the king heard this, he was troubled, and all Jerusalem with him. {4} And when he had gathered all the chief priests and scribes of the people together, he inquired of them where the Christ was to be born.

{5} So they said to him, "In Bethlehem of Judea, for thus it is written

by the prophet: {6} 'But you, Bethlehem, in the land of Judah, Are not the least among the rulers of Judah; For out of you shall come a Ruler Who will shepherd My people Israel.'"

{7} Then Herod, when he had secretly called the wise men, determined from them what time the star appeared. {8} And he sent them to Bethlehem and said, "Go and search carefully for the young Child, and when you have found Him, bring back word to me, that I may come and worship Him also."

{9} When they heard the king, they departed; and behold, the star which they had seen in the East went





before them, till it came and stood over where the young Child was.

{10} When they saw the star, they rejoiced with exceedingly great joy. {11} And when they had come into the house, they saw the young Child with Mary His mother, and fell down and worshiped Him. And when they had opened their treasures, they presented gifts to Him: gold, frankincense, and myrrh.

{12} Then, being divinely warned in a dream that they should not return to Herod, they departed for their own country another way.

{13} Now when they had departed, behold, an angel of the Lord appeared to Joseph in a dream, saying, "Arise, take the young Child and His mother, flee to Egypt, and stay there until I bring you word; for Herod will seek the young Child to destroy Him."

{14} When he arose, he took the young Child and His mother by night and departed for Egypt, {15} and was there until the death of Herod, that it might be fulfilled which was spoken by the Lord through the prophet, saying, "Out of Egypt I called My Son."

{16} Then Herod, when he saw that he was deceived by the wise men, was exceedingly angry; and he sent

forth and put to death all the male children who were in Bethlehem and in all its districts, from two years old and under, according to the time which he had determined from the wise men.

{17} Then was fulfilled what was spoken by Jeremiah the prophet, saying: {18} "A voice was heard in Ramah, Lamentation, weeping, and great mourning, Rachel weeping for her children, Refusing to be comforted, Because they are no more."

{19} But when Herod was dead, behold, an angel of the Lord appeared in a dream to Joseph in Egypt, {20} saying, "Arise, take the young Child and His mother, and go to the land of Israel, for those who sought the young Child's life are dead."

{21} Then he arose, took the young Child and His mother, and came into the land of Israel. {22} But when he heard that Archelaus was reigning over Judea instead of his father Herod, he was afraid to go there. And being warned by God in a dream, he turned aside into the region of Galilee.

{23} And he came and dwelt in a city called Nazareth, that it might be fulfilled which was spoken by the prophets, "He shall be called a Nazarene."

---

### **Outer Aim - God led the wise men to Jesus.**

---

**What the Story Tells Us** - Fill in the blanks to complete these sentences about the story.

1. The wise men went to \_\_\_\_\_ looking for Jesus.
2. \_\_\_\_\_ was afraid this new King would take away his kingdom.

3. His scribes found in the \_\_\_\_\_ the answer of where the King was to be born.
4. Herod told the wise men that he wanted to \_\_\_\_\_ the child.
5. The star led them to the town of \_\_\_\_\_.
6. When the wise men had worshiped Jesus they gave Him \_\_\_\_\_, \_\_\_\_\_, and \_\_\_\_\_.
7. God kept Jesus safe by telling the wise men in a \_\_\_\_\_ to go home by a different way.
8. This angered \_\_\_\_\_ and he commanded that all male babies should be \_\_\_\_\_.
9. Jesus was kept safe because God had warned \_\_\_\_\_ in a \_\_\_\_\_.
10. After \_\_\_\_\_ was dead God sent His \_\_\_\_\_ again to Joseph in a dream.
11. Joseph moved Mary and Jesus to \_\_\_\_\_.

### **What God's Word Tells Us** - How do these passages parallel today's story?

Isaiah 60:2-3 - For behold, the darkness shall cover the earth, and deep darkness the people; but the LORD will arise over you, and His glory will be seen upon you. The Gentiles shall come to your light, and kings to the brightness of your rising.

Micah 5:2 - But you, Bethlehem Ephrathah, though you are little among the thousands of Judah, yet out of you shall come forth to Me the One to be Ruler in Israel, whose goings forth are from of old, from everlasting.

---

**Inner Aim - God reveals the Savior of all people.**

---

## Passages

"Commit your way to the LORD, trust also in Him, and He shall bring it to pass."  
Psalm 37:5

Isaiah 49:6 - Indeed He says, "I will also give You as a light to the Gentiles, that You should be my salvation to the ends of the earth."

## Hymn Study - TLH 127

As with gladness men of old  
Did the guiding star behold;  
As with joy they hailed its light,  
Leading onward, beaming bright,  
So, most gracious Lord, may we  
Evermore be led by Thee!

As with joyful steps they sped,  
Savior, to Thy lowly bed,  
There to bend the knee before  
Thee whom heav'n and earth adore,  
So may we with willing feet  
Ever seek Thy mercyseat!

As they offered gifts most rare  
At Thy cradle, rude and bare,  
So may we with holy joy,  
Pure and free from sin's alloy.  
All our costliest treasures bring,  
Christ, to Thee, our heav'nly King!

Holy Jesus, every day  
Keep us in the narrow way;  
And, when earthly things are past,  
Bring our ransomed souls at last  
Where they need no star to guide,  
Where no clouds Thy glory hide.

In the heavenly country bright need they no created light;  
Thou its Light, its Joy, its Crown, Thou its Sun which goes not down.  
There forever may we sing alleluias to our King!

Which verses specifically apply to today's lesson?  
How can we learn from the wise men's actions?

**Prayer** - Write a prayer that focuses on the thoughts of today's lesson.

## Twelve-year-old Jesus in the Temple

Luke 2:40-52

What do you think the boy Jesus is doing?

Do you think He is happy to be there? Why or why not?

### Prayer

Dear Lord,

Make our hearts willing to hear Your Word. Let us joyfully use the opportunities we are given to learn Your Word. Help us to treasure it and remain Your children throughout our lives. Help us to always obey You and our earthly superiors. Amen.

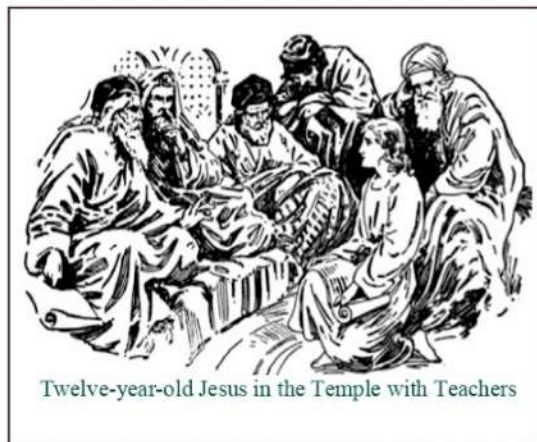

Twelve-year-old Jesus in the Temple with Teachers

### Twelve-year-old Jesus in the Temple - Luke 2: 40-52

And the Child grew and became strong in spirit, filled with wisdom; and the grace of God was upon Him. {41} His parents went to Jerusalem according to the custom of the [Passover] feast.

{43} When they had finished the days, as they returned, the boy Jesus lingered behind in Jerusalem. And Joseph and His mother did not know it; {44} but supposing Him to have been in the company, they went a day's journey, and sought Him among their relatives and acquaintances. {45} So when they did not find Him, they returned to Jerusalem, seeking Him.

{46} Now so it was that after three

days they found Him in the temple, sitting in the midst of the teachers, both listening to them and asking them questions. {47} And all who heard Him were astonished at His understanding and answers.

{48} So when they saw Him, they were amazed; and His mother said to Him, "Son, why have You done this to us? Look, Your father and I have sought You anxiously." {49} And He said to them, "Why did you seek Me? Did you not know that I must be about My Father's business?" {50} But they did not understand the statement which He spoke to them.

{51} Then He went down with



them and came to Nazareth, and was subject to them, but His mother kept all these things in her heart. {52} And Jesus

increased in wisdom and stature, and in favor with God and men.

---

**Outer Aim The Boy Jesus came to do His heavenly Father's business.**

---

**What the Story Tells Us** - Tell whether the sentences are True or False. Correct the false statements.

1. \_\_\_\_\_ Jesus went to Nazareth with His parents for the feast of the Passover.
2. \_\_\_\_\_ After the feast, Jesus lingered behind in Jerusalem.
3. \_\_\_\_\_ Jesus did not tire of listening to God's Word.
4. \_\_\_\_\_ After one day Joseph and Mary found Jesus.
5. \_\_\_\_\_ Jesus was learning God's Word from the teachers.
6. \_\_\_\_\_ Jesus was doing His heavenly Father's work.
7. \_\_\_\_\_ Jesus obeyed His parents.

**What God's Word Tells Us** - Circle the word in each statement that makes it correct.

1. God wants us to (despise, treasure, bury) His Word.
2. God's Word has (no errors, a lot of errors, just a few unimportant errors).
3. It is good for us to hear God's Word (when it is convenient, sometimes, continually).
4. We should hear and learn God's Word (eagerly, reluctantly, half-heartedly).

---

**Inner Aim Jesus willingly treasured God's Word perfectly for us.**

---

**Your Turn** - Use the commandments and passage below to answer the questions.

4<sup>th</sup> Commandment

Honor your father and mother that it may be well with you  
and you may live long on the earth.

How did Jesus in this lesson obey this commandment?

3<sup>rd</sup> Commandment

Remember the Sabbath day to keep it holy.

How did Jesus in this lesson obey this commandment?

Psalms 84:10 - For a day in Your courts is better than a thousand.  
I would rather be a doorkeeper in the house of my God  
than dwell in the tents of wickedness.

Explain how this passage applies to the story.

## Passages

Psalm 122:1 - I was glad when they said to me, "Let us go into the house  
of the Lord."

Luke 11:28 - (Jesus said) "Blessed are those who hear the word of God  
and keep it!"

Psalm 119:105 - Your word is a lamp to my feet and a light to my path.

## Hymn - TLH 297 v. 1, 3, 4, 6

The Gospel shows the Father's grace,  
Who sent His Son to save our race,  
Proclaims how Jesus lived and died  
That man might thus be justified.

It brings the Savior's righteousness  
Our souls to robe in royal dress;  
From all our guilt it brings release  
And gives the troubled conscience peace.

It is the pow'r of God to save  
From sin and Satan and the grave;  
It works the faith, which firmly clings  
To all the treasures which it brings.

May we in faith its tidings learn  
Nor thanklessly its blessings spurn;  
May we in faith its truth confess  
And praise the Lord our Righteousness!

## Prayer

Dear Father in heaven,

Even as a little child, Jesus did Your will and worked for our salvation. Help us to live thankful lives, eager to hear Your Word, and to obey not only You but those whom You have placed over us for our care. And when we fall, bring us back to You in repentance and faith, trusting in Your forgiveness and the salvation that Jesus, Your Son through His perfect obedience, gained for us. We pray, trusting in Jesus, Amen.

# The Ministry of John and the Baptism of Jesus

Matthew 3:1-17

*"The voice of one crying in the wilderness: Prepare the way of the LORD. Make straight in the desert a highway for our God." Isaiah 40:3b*

This passage is a prophecy about John the Baptist. We will learn today how this prophecy was fulfilled.

## Prayer

Dear Heavenly Father,

Thank You for showing us, through our study of His baptism, that Jesus is Your Son sent to be our Savior. Help us to picture in our hearts Jesus' baptism and how He kept the Law for us, to be our perfect Savior. When we sin, call us to repentance. Help us to understand that in our baptism Jesus washed us clean from all our sin and worked faith in our hearts. Keep us in that faith throughout our lives, we pray. Amen

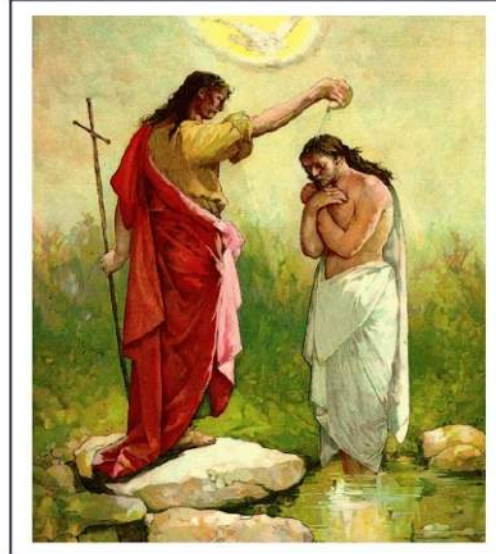

*The Baptism of Jesus*

## The Story

John was the son of Zacharias and Elizabeth. John and Jesus were relatives. As the forerunner of the Messiah, John was God's last prophet for the children of Israel.

John lived in the wilderness. He wore camel's hair for clothes, with a belt around his waist. He ate grasshoppers and wild honey. He preached to many people from Jerusalem and Judea, telling them to repent of their sins and be baptized. That is why he is called John the Baptist. His job was to get people ready for the coming of Jesus.

One day some Pharisees came, and John called them a "brood of vipers," meaning they were as dangerous as poisonous snakes. He knew they did not believe in the promise of the coming Messiah. They thought they would be saved because they were born from Abraham's line. John warned these men that if they did not have faith they were like a tree that would be burned because it did not bear fruit.

On another day John saw Jesus coming to be baptized. John said,

**God's Hand in Our Lives**  
New Testament

*The Ministry of John/Baptism of Jesus - Level 3*

8/19/04





"Behold, the Lamb of God who takes away the sins of the world!" John did not think he was worthy enough to baptize Jesus. Jesus commanded John to do it, and John obeyed. When the baptism was over, the Holy Spirit landed on Jesus in the form of a dove. From the sky came the voice of

God the Father saying, "You are my beloved Son; in You I am well pleased." All three persons of God were present at this baptism. The words were from the Father, Jesus was and is the Son, and the dove was the Holy Spirit.

---

**Outer Aim** Jesus was baptized to publicly begin His ministry as our Savior.

---

**What the Story Tells Us** - Use the Bible references to answer the questions

1. What name did the prophet give John?(Mk. 1:2)
2. What did the prophet say John would do?(2-3)
3. Where did John preach and baptize?(4)
4. What did John preach?(4)
5. Who came to hear John?(5)
6. What did John wear?(6)
7. What did he eat?(6)
8. What did John call the Pharisees, Sadducees?(Mt.3:7)
9. What did he tell them to do?(8)
10. What did John say about Jesus?(11)
11. Who came to be baptized by John?(13)
12. What did John think about this?(14)
13. What happened after Jesus was baptized?(16-17)
14. What did Jesus now begin?(Lk. 3:23)
15. How old was Jesus at this time?(23)

## What God's Word Tells Us

Why do we get baptized? (check Mt. 28:19 and Acts 22:16)

Why did Jesus get baptized? (check Mt. 3:15)

**Your Turn**- Place an X in front of each True statement.

1.  John the Baptist lived and preached in the city.
2.  John the Baptist preached about repentance.
3.  John the Baptist wanted Jesus to baptize him.
4.  Jesus baptized John.

---

**Inner Aim** God declared Jesus to be the Promised Messiah, our Savior.

---

## Passages

John 3:16 - "For God so loved the world that He gave His only begotten Son, that whoever believes in Him should not perish but have everlasting life."

1 John 1:7, 9 - "The blood of Jesus Christ His Son cleanses us from all sin. If we confess our sins, He is faithful and just to forgive us our sins and to cleanse us from all unrighteousness."

Ephesians 5:25-26 - "Christ also loved the church and gave Himself for her, that He might sanctify and cleanse her with the washing of water by the word."

**Puzzle Time** - Find these words in the puzzle below.

JOHN THE BAPTIST	JORDAN	CAMEL	DOVE
WILDERNESS	LOCUST	VOICE	VIPERS
REPENTANCE	PHARISEE	SADDUCEE	GOD

D A Y R I L H H H F E S I J V W V  
B O M D P H A R I S E E R G P I G  
B T V O I C E D R A J U Y C P L Q  
V Y K E L A J Z T D H I T E O D W  
C C J I K W O G O D F R R V I E E  
U A F P H E R X Y U S S P B I R R  
Y M S I G R D L O C U S T N U N T  
R E P E N T A N C E A T O M U E T  
E L R J O H N T H E B A P T I S T  
I O E U F D Z C Y T W Y O M Y S Y

**Hymn/Prayer** - TLH 63 v. 1, 5

On Jordan's bank the Baptist's cry  
Announces that the Lord is nigh;  
Come, then, and hearken,  
For He brings  
Glad tidings from the King of kings.

All praise, eternal Son, to Thee  
Whose advent sets Thy people free,  
Whom, with the Father, we adore  
And Holy Ghost  
Forevermore. Amen.

## The Temptations in the Wilderness

Matthew 4:1-11; Mark 1:12-13; Luke 4:1-13

Who is the devil? The devil is that fallen angel who was thrown out of heaven and seeks his revenge by introducing and expanding sin into the world. The devil also tempted Jesus. If the devil could have successfully led Jesus to sin, then Jesus could not have been our Savior and no one else could deliver us from sin, death, and the power of the devil.

How did Jesus defeat the devil? He used the same weapon He has given us - His Word, the Bible. Thanks be to God who gives us the victory over the devil!

### Prayer

Lord, open Thou my heart to hear  
And through Thy Word to me draw near;  
Let me Thy Word e'er pure retain,  
Let me Thy child and heir remain. Amen.

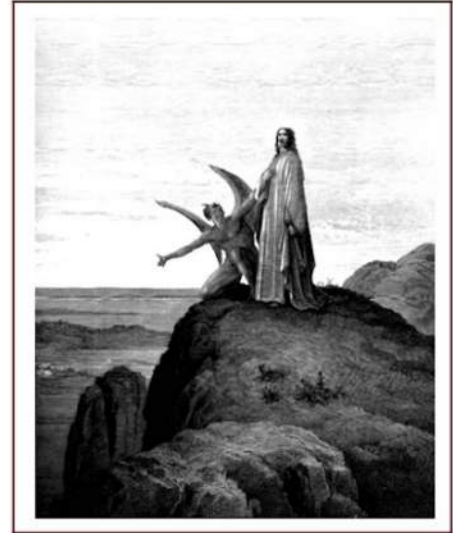

### The Story - Luke 4:1-11

Then Jesus was led up by the Spirit into the wilderness to be tempted by the devil.<sup>2</sup> And when He had fasted forty days and forty nights, afterward He was hungry.<sup>3</sup> Now when the tempter came to Him, he said, "If You are the Son of God, command that these stones become bread."

<sup>4</sup>But He answered and said, "It is written, 'Man shall not live by bread alone, but by every word that proceeds from the mouth of God.'"

<sup>5</sup>Then the devil took Him up into the holy city, set Him on the pinnacle of the temple,<sup>6</sup> and said to Him, "If You are

the Son of God, throw Yourself down. For it is written: 'He shall give His angels charge over you,' and, 'In their hands they shall bear you up, lest you dash your foot against a stone.'"

<sup>7</sup>Jesus said to him, "It is written again, 'You shall not tempt the LORD your God.'"

<sup>8</sup>Again, the devil took Him up on an exceedingly high mountain, and showed Him all the kingdoms of the world and their glory.<sup>9</sup> And he said to Him, "All these things I will give You if You will fall down and worship me."

<sup>10</sup>Then Jesus said to him, "Away



with you, Satan! For it is written, 'You shall worship the LORD your God, and Him only you shall serve.'"

<sup>11</sup>Then the devil left Him, and behold, angels came and ministered to Him.

---

**Outer Aim - Jesus did not sin when the devil tempted Him.**

---

**What the Story Tells Us** - Answer these questions about the lesson. The Bible reference in ( ) parentheses will help you.

1. Where did the Spirit lead Jesus? (Mt. 4:1) \_\_\_\_\_
2. Why did the Spirit lead Jesus there? (1) \_\_\_\_\_
3. What did Jesus do for forty days and nights? (2) \_\_\_\_\_
4. How did Jesus feel after fasting for so long? (2) \_\_\_\_\_
5. What is the first temptation we read about? (3) \_\_\_\_\_
6. What did Jesus say to Satan? (4) \_\_\_\_\_
7. Where did Satan then take Jesus? (5) \_\_\_\_\_
8. How did Satan tempt Jesus here? (6) \_\_\_\_\_
9. What did Satan use in his temptation? (6) \_\_\_\_\_
10. What did Jesus say to Satan? (7) \_\_\_\_\_
11. Where did Satan take Jesus in verse 8? \_\_\_\_\_
12. What did Satan show Jesus? (8) \_\_\_\_\_
13. How did Satan now tempt Jesus? (9) \_\_\_\_\_
14. What did Jesus say to this? (10) \_\_\_\_\_
15. Who came to help Jesus after Satan left? (11) \_\_\_\_\_

**What God's Word Tells Us** - Discuss how each of the following is a good way to deal with temptation.

- |                     |   |
|---------------------|---|
| a) God's Word       | d) Avoiding people or places which may bring temptation |
| b) Prayer           | e) Other...   |
| c) Christian advice |   |

**Your Turn** - Circle the correct letter for each sentence below.

1. Jesus was led into the wilderness by the \_\_\_\_\_. a) angels b) devil c) Spirit
2. Jesus fasted \_\_\_\_ days and nights. a) twenty b) forty c) sixty
3. Satan tempted Jesus to serve Himself by turning stones into \_\_\_\_\_. a) bread b) rocks c) a bed
4. Satan tempted Jesus to jump off the temple by quoting the \_\_\_\_\_. a) Bible b) chief priests c) scribes
5. Satan offered Jesus the world if He would \_\_\_\_\_ him. a) love b) save c) worship

**Word Find** - Find the following words in the puzzle below

WILDERNESS  
TEMPTATION

KINGDOMS  
MOUNTAIN  
HUNGER

BREAD  
FORTY

FASTED  
SAVIOR  
SATAN

PINNACLE  
STONES

A M N B V C F G T R R R E S W Q W E  
 E R K H H H L J J J H E W T D F E G  
 U P I N N A C L E Y T T Y O E R T Y  
 R T N T T E M P T A T I O N T Y R T  
 Q Q G R W E O Q K F L I U E T Y S Q  
 K J D W X Z U X B O R E D S A T A N  
 F Y O R H U N G E R X C V B N M V L  
 O A M P I U T T R T E E Q Q W X I Z  
 D F S I L T A X E Y T A G H U K O K  
 L I I T W A I Z X C W E D R T Y R L  
 W I L D E R N E S S L K J U Y H T G  
 F O R D E D H I S O R S E O R H L X

---

## Inner Aim - Jesus overcame the devil for us.

---

### Passages

Matthew 26:41 - "Watch and pray, lest you enter into temptation. The spirit indeed is willing, but the flesh is weak."

1 Peter 5:8 - "Be sober, be vigilant; because your adversary the devil walks about like a roaring lion, seeking whom he may devour."

Hebrews 4:15 - "(Jesus) was in all points tempted as we are, yet without sin."

### Hymn - TLH 446 v. 1, 5, 6

Rise, my soul, to watch and pray,  
From thy sleep awaken;  
Be not by the evil day  
Unawares o'ertaken.  
For the Foe, well we know,  
Oft his harvest reapeth  
While the Christian sleepeth.

But while watching, also pray  
To the Lord unceasing.  
He will free thee, be thy Stay,  
Strength and faith increasing.  
O Lord, bless in distress  
And let nothing swerve me  
From the will to serve Thee.

Therefore let us watch and pray, knowing He will hear us  
As we see from day to day dangers ever near us,  
And the end doth impend —  
Our redemption neareth when the Lord appeareth.

### Prayer

Dear Heavenly Father,

Even as we pray in the Lord's Prayer, "Lead us not into temptation, but deliver us from evil," so deliver us from temptation and evil. Strengthen our faith and increase our knowledge of Your Word that we, by Your Grace, may overcome the Devil through Jesus' victory for us. Forgive us where we have fallen. We pray, believing in the name of Jesus our victorious Savior, Amen.

## The Wedding at Cana

John 2:1-12

For what things do you pray?

To whom do Christians pray?

Why do you believe that God can answer your prayer?

### Prayer

Dear God,

Our Father in Heaven, through this awesome miracle that Jesus did, help us to see that He was not only a good man but also the Son of God come to earth to be our Savior. Teach us to turn to Jesus for our needs. Help us to know that He will meet those needs in the way that is best for us. O Lord, bless our homes with Your presence and strengthen our trust in You for forgiveness of sins and all that we need. In Jesus' name we pray, Amen.



### The Wedding at Cana - John 2:1-12

On the third day there was a wedding in Cana of Galilee, and the mother of Jesus was there. {2} Now both Jesus and His disciples were invited to the wedding. {3} And when they ran out of wine, the mother of Jesus said to Him, "They have no more wine." {4} Jesus said to her, "Woman, what does your concern have to do with Me? My hour has not yet come." {5} His mother said to the servants, "Whatever He says to you, do it."

{6} Now there were set there six water pots of stone, according to the

manner of purification of the Jews, containing twenty or thirty gallons apiece. {7} Jesus said to them, "Fill the water pots with water." And they filled them up to the brim. {8} And Jesus said to them, "Draw some out now, and take it to the master of the feast." And they took it.

{9} When the master of the feast had tasted the water that was made wine, and did not know where it came from (but the servants who had drawn the water knew), the master of the feast called the bridegroom. {10} And he said to him, "Every man at the beginning sets





out the good wine, and when the guests have well drunk, then that which is inferior; but you have kept the good wine until now."

{11} This beginning of signs Jesus did in Cana of Galilee, and manifested His glory; and His disciples believed in Him. {12} After this He went down to Capernaum, He, His mother, His brothers, and His disciples; and they did not stay there many days.



---

**Outer Aim - Jesus changed water into wine to show He is God.**

---

**What the Story Tells Us** - Fill in the blanks.

1. A wedding took place at Cana. Cana was in \_\_\_\_\_.
2. When the wine ran out, Jesus' mother went to Jesus and said, "\_\_\_\_\_."
3. Jesus said to her, "My \_\_\_\_\_ has not yet come."
4. Jesus told the \_\_\_\_\_ to fill six pots with \_\_\_\_\_.
5. He then told them to take some to the \_\_\_\_\_.
6. When the master tasted the water, it was already made into \_\_\_\_\_.
7. This miracle manifested (showed) Jesus' \_\_\_\_\_ and His disciples \_\_\_\_\_ in Him.

**What God Tells Us** - Mark each statement (T) if it is true or (F) if it is false and make the false statements true.

1. \_\_\_\_ Jesus changed water into wine because His mother told Him to.
2. \_\_\_\_ Jesus changed water into wine to impress the wedding guests.
3. \_\_\_\_ Only God could change water into wine.
4. \_\_\_\_ Jesus was only a man.
5. \_\_\_\_ Because Jesus is God, we can be sure He will protect and provide for us.
6. \_\_\_\_ Jesus had to be true God in order to pay for our sins.
7. \_\_\_\_ This lesson teaches us that Jesus will give us whatever we ask for, no matter what.
8. \_\_\_\_ The disciples' faith was strengthened after witnessing this miracle.
9. \_\_\_\_ God tells us about Jesus' miracles to strengthen our faith also.

**Passages** - Look up the following passages and insert the missing words.

Psalm 50:15 - Call upon \_\_\_\_\_ in the day of \_\_\_\_\_; I will  
\_\_\_\_\_ you, and you shall \_\_\_\_\_ Me.

Genesis 2:24 - Therefore a man shall leave his \_\_\_\_\_ and  
\_\_\_\_\_ and be \_\_\_\_\_ to his wife, and they shall become  
\_\_\_\_\_ flesh.

---

**Inner Aim - Jesus' miracles support our faith that He is God and will take care of our needs.**

---

## Hymn - TLH 426

The Lord my Shepherd is,  
I shall be well supplied.  
Since He is mine and I am His,  
What can I want beside?

He leads me to the place  
Where heav'nly pasture grows,  
Where living waters gently pass  
And full salvation flows.

If e'er I go astray,  
He doth my soul reclaim  
And guides me in His own right way  
For His most holy name.

While He affords His aid,  
I cannot yield to fear;  
Though I should walk through death's dark shade,  
My Shepherd's with me there.

Amid surrounding foes  
Thou dost my table spread;  
My cup with blessing overflows,  
And joy exalts my head.

The bounties of Thy love  
Shall crown my following days,  
Nor from Thy house will I remove  
Nor cease to speak Thy praise.

Which stanzas of hymn 426 might you use to explain to someone that Jesus will provide for their needs? Explain why you chose each of those stanzas.

**Your Turn** - Use ideas from the story, passages, and the hymn you read today to complete the following activity.

A friend comes to you and explains that her grandmother is very sick and is discouraged that her prayer to God for her to get better doesn't seem to be working. What could you say to your friend?

**Prayer** - Write a prayer that expresses the things you learned from this lesson. You may work with other members of the class.

## Peter's Catch of Fish and Jesus' Call of the Apostles

Luke 5:1-11, 6:12-16; Matthew 4: 18-22, 10: 1-10; Mark 3: 13-14

What are these children doing?

Who gives the children the ability to do schoolwork well?

Why might someone feel like he doesn't have the ability to do something?

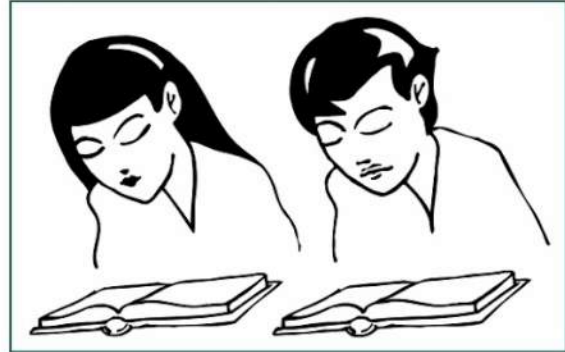

### Prayer

Dear Jesus in Heaven,

Thank You for calling people to serve You by teaching us Your Word. We know that You have given each of us a calling for our lives, to serve You. Help us to spread Your Word so that many will become believers in You and be saved. When we fail to serve You, send others to call us to repent and to bring us Your Word and forgiveness, which You won for us by Your redeeming death on the cross. In Your saving name we pray, Amen.

## Peter's Catch of Fish and Jesus' Call of the Apostles

Now so it was, as the multitude pressed about Him to hear the word of God, that He stood by the Lake of Gennesaret, and saw two boats standing by the lake; but the fishermen had gone from them and were washing their nets.

Then He got into one of the boats, which was Simon's, and asked him to put out a little from the land. And He sat down and taught the multitudes from the boat.

Now when He had stopped speaking, He said to Simon, "Launch

out into the deep and let down your nets for a catch."

But Simon answered and said to Him, "Master, we have toiled all night and caught nothing; nevertheless at Your word I will let down the net." And when they had done this, they caught a great number of fish and their net was breaking.

So Simon and Andrew his brother signaled to their partners in the other boat to come and help them. And they came and filled



both the boats, so that they began to sink.

When Simon Peter saw it, he fell down at Jesus' knees, saying, "Depart from me, for I am a sinful man, O Lord!" For he and all who were with him were astonished at the catch of fish which they had taken; and so also were James and John, the sons of Zebedee, who were partners with Simon.

And Jesus said to them, "Do not be afraid. Follow me, and I will make you fishers of men."

So when they had brought their boats to land, they forsook all, including their boats, their nets, and their father, and followed Him.

Now it came to pass in those days that He went out to a mountain to pray, and continued all night in prayer to God.

And when it was day, He called His disciples to Him, those whom He Himself wanted; and from them He chose twelve whom He also named apostles. He appointed

them that they might be with Him and that He might send them out to preach.

Now the names of the twelve apostles are these: Simon, whom He also named Peter, and Andrew his brother; James the son of Zebedee, and John his brother; Philip and Bartholomew; Thomas and Matthew the tax collector; James the son of Alphaeus; Thaddeus; Simon called the Zealot; and Judas Iscariot, who also betrayed Him.



**What the Story Tells Us** - For each statement mark (T) for true and (F) for false.

- \_\_\_\_\_ 1. The multitude pressed about Him to see His miracles.
- \_\_\_\_\_ 2. Jesus preached to the multitudes from John's boat.
- \_\_\_\_\_ 3. Jesus told Simon to go into deep water and let down their nets.
- \_\_\_\_\_ 4. Simon didn't do what Jesus said.
- \_\_\_\_\_ 5. They caught so many fish, that their nets broke and their boats almost sank.
- \_\_\_\_\_ 6. Simon and the others thought nothing of the great catch of fish.

- \_\_\_\_\_ 7. Jesus called them fishers of men.
- \_\_\_\_\_ 8. Jesus later chose twelve men to be apostles.

---

**Outer Aim - Jesus called some fishermen to preach the Gospel.**

---

**What God tells Us**

1. Why did Simon seem amazed when Jesus asked him to go out into deep water and fish?
2. What did Simon also say that showed his faith?
3. Who had allowed these men to catch all those fish?
4. What did Jesus mean when He said "I will make you fishers of men." ?
5. How did Jesus' miracle show the disciples that they could be fishers of men if they followed Jesus?
6. Name some types of people that God has especially called to be "fishers of men".Where do they get the ability to serve Him?

**Passages** - Explain how each of these passages fits the story.

Matthew 6:33 - But seek first the kingdom of God and His righteousness, and all these things shall be added to you.

Matthew 16:24-25 - Then Jesus said to His disciples, "If anyone desires to come after Me, let him deny himself, and take up his cross, and follow Me. For whoever desires to save his life will lose it, but whoever loses his life for My sake will find it."

Philippians 1:6 - Being confident of this very thing, that He who has begun a good work in you will complete it until the day of Jesus Christ.

---

**Inner Aim - Jesus gives those He calls the power to preach the Gospel.**

---

## Hymn - TLH 493

Thou who the night in prayer didst spend  
And then didst Thine apostles send  
And bidd'st us pray the harvest's Lord  
To send forth sowers of Thy Word,  
Hear and Thy chosen servants bless  
With sev'nfold gifts of holiness.

Oh, may Thy pastors faithful be,  
Not lab'ring for themselves, but Thee!  
Give grace to feed with wholesome food  
The sheep and lambs bought by Thy blood,  
To tend Thy flock, and thus to prove  
How dearly they the Shepherd love.

Oh, may Thy people faithful be  
And in Thy pastors honor Thee  
And with them work and for them pray  
And gladly Thee in them obey,  
Receive the prophet of the Lord  
And gain the prophet's own reward!

So may we when our work is done  
Together stand before Thy throne  
And joyful hearts and voices raise  
In one united song of praise,  
With all the bright celestial host,  
To Father, Son, and Holy Ghost.

Look at hymn 493 v. 1 and explain what part of the story it is speaking of.  
Then choose one of the other verses and write it in you own words.

**Your Turn** - Someday, the Lord might call you to be a pastor or a teacher, but if He does not, how can you still be "fishers of men"? Use ideas from the story, passages and hymn to answer the question.

**Prayer** - Use the main ideas from the lesson, especially the inner aim, to write a short prayer of your own.

## Jesus and Nicodemus

John 3:1-21

Almost everyone came into the world by being born. Adam and Eve are the only people who were not born. Everyone who has been born into the world has only been born once. Jesus tells us that those who are believers are born twice! It is hard for us as humans to understand this, but Jesus explains it to us in the Bible. He explains it to a man named Nicodemus, a man who was a Rabbi, or a teacher in the church.

Today, we will learn how a person can be born twice, as we study Jesus' conversation with Nicodemus.



### Prayer

Let me learn of Jesus; He is kind to me.  
Once He died to save me, Nailed upon the tree.  
Let me think of Jesus; He is full of love,  
Looking down upon me From His throne above. Amen.

### The Story - John 3:1-21

There was a man of the Pharisees named Nicodemus, a ruler of the Jews. {2} This man came to Jesus by night and said to Him, "Rabbi, we know that You are a teacher come from God; for no one can do these signs that You do unless God is with him."

{3} Jesus answered and said to him, "Most assuredly, I say to you, unless one is born again, he cannot see the kingdom of God."

{4} Nicodemus said to Him, "How can a man be born when he is old? Can he enter a second time into his mother's womb and be born?"

{5} Jesus answered, "Most assuredly, I say to you, unless one is born of water and the Spirit, he cannot enter the kingdom of God. {6} "That which is born of the flesh is flesh, and that which is born of the Spirit is spirit. {7} "Do not marvel that I said to you, 'You must be born again.' {8} "The wind blows where it wishes, and you hear the sound of it, but cannot tell where it comes from and where it goes. So is everyone who is born of the Spirit."

{9} Nicodemus answered and said to Him, "How can these things be?"

{10} Jesus answered and said to him, "Are you the teacher of Israel, and do not





know these things? {11} "Most assuredly, I say to you, We speak what We know and testify what We have seen, and you do not receive Our witness. {12} "If I have told you earthly things and you do not believe, how will you believe if I tell you heavenly things? {13} "No one has ascended to heaven but He who came down from heaven, that is, the Son of Man who is in heaven. {14} "And as Moses lifted up the serpent in the wilderness, even so must the Son of Man be lifted up, {15} "that whoever believes in Him should not perish but have eternal life.

{16} "For God so loved the world that He gave His only begotten Son, that whoever believes in Him should not perish but have everlasting life. {17} "For God did not send His Son into the world to condemn the world, but that the world

through Him might be saved. {18} "He who believes in Him is not condemned; but he who does not believe is condemned already, because he has not believed in the name of the only begotten Son of God. {19} "And this is the condemnation, that the light has come into the world, and men loved darkness rather than light, because their deeds were evil. {20} "For everyone practicing evil hates the light and does not come to the light, lest his deeds should be exposed. {21} "But he who does the truth comes to the light, that his deeds may be clearly seen, that they have been done in God."

**Outer Aim - Jesus reveals the nature of the Kingdom of God to Nicodemus.**

**What God's Word Tells Us** - Look up Titus 3:4-7. Fill in the blanks.

But when the \_\_\_\_\_ and the love of God our \_\_\_\_\_ toward \_\_\_\_\_ appeared, not by \_\_\_\_\_ of \_\_\_\_\_ which we have done, but according to His \_\_\_\_\_ He \_\_\_\_\_ us, through the \_\_\_\_\_ of \_\_\_\_\_ and \_\_\_\_\_ of the \_\_\_\_\_, whom he \_\_\_\_\_ out on us abundantly through \_\_\_\_\_ our \_\_\_\_\_, that having been \_\_\_\_\_ by His \_\_\_\_\_ we should become \_\_\_\_\_ according to the \_\_\_\_\_ of eternal \_\_\_\_\_.

**Inner Aim - Jesus has made me a part of His Kingdom by water and the Spirit.**

**What the Story Tells Us** - Find the words in the word search. The words may be vertical, horizontal, diagonal, and even backwards.

RABBI	NICODEMUS	KINGDOM OF GOD	SERPENT	WATER
FLESH	REGENERATE	EVERLASTING LIFE	SPIRIT	MOSES
JESUS	SANHEDRIN	BORN AGAIN	PERISH	SAVIOR
WIND	SON OF MAN	BEGOTTEN		

S A S I J K R D J E B S S E Q P L I X  
O R A B B I U T S B O A F J E S U S N  
N E V A W N N M K O R N T D E R T H I  
O R I F L E S H A A N H E F G H B B C  
F T O F P E R I S H A E D O I G E U O  
M H R R E E N K I N G D O M O F G O D  
A V E J O E T A N W A R P O Y H O T E  
N S G U S K C I R R I I R N F X T Y M  
R E G E N E R A T E N N F W J Z T H U  
D S Q W E R O H J K O O D T A L E G S  
E O A S D T I R I P S V B S J T N B S  
S M S D T B N J T W O D Y S R M E N J  
R E E F I L G N I T S A L R E V E R D

**Passages** - Explain the following passages as if you were talking to a friend who didn't know about Jesus.

John 3:16 - For God so loved the world that He gave his only begotten Son, that whoever believes in Him should not perish, but have everlasting life.

John 3:5 - Jesus answered, "Most assuredly, I say to you, unless one is born of water and the Spirit, he cannot enter the kingdom of God."

## Hymn - TLH #245

God loved the world so that He gave  
His only Son the lost to save.  
That all who would in Him believe,  
Should everlasting life receive.

Christ Jesus is the Ground of faith,  
Who was made flesh and suffered death;  
All that confide in Him alone  
Are built on this chief Cornerstone.

God would not let the sinner die,  
His Son with saving grace is nigh,  
His Spirit in the Word doth teach  
How man the blessed goal may reach.

Be of good cheer, for God's own Son  
Forgives all sins which thou hast done,  
And justified by Jesus' blood,  
Thy Baptism grants the highest good.

If thou be sick, if death draw near,  
This truth thy troubled heart can cheer:  
Christ Jesus saves my soul from death;  
That is the firmest ground of faith.

Glory to God the Father, Son,  
And Holy Spirit, Three in One!  
To Thee, O blessed Trinity,  
Be praise now and eternally! Amen.

## Prayer

Grant us Thy peace upon our homeward way  
With Thee began with Thee shall end the day.  
Guard Thou the lips from sin, the hearts from shame,  
That in this house have called upon Thy name. Amen (TLH #47 v 2)

# Jesus and the Samaritan Woman

John 4

Which of these people has a Savior? How do you know? We will learn about a woman today who is one of those saved because of Jesus.

## Prayer

Dear Jesus, Help us to understand Your perfect love for all people. We thank You that You came to seek and to save those who were lost. We ask that You would bless our study this morning so that we may understand Your grace in our lives. Help us never to look down on or despise any other person. Thank You. Amen.



## The Story

Therefore, when the Lord knew that the Pharisees had heard that Jesus made and baptized more disciples than John {2} (though Jesus Himself did not baptize, but His disciples), {3} He left Judea and departed again to Galilee. {4} But He needed to go through Samaria.

{5} So He came to a city of Samaria which is called Sychar, near the plot of ground that Jacob gave to his son Joseph. {6} Now Jacob's well was there. Jesus therefore, being wearied from His journey, sat thus by the well. It was about the sixth hour.

{7} A woman of Samaria came to draw water. Jesus said to her, "Give Me a drink." {8} For His disciples had gone away into the city to buy food.

{9} Then the woman of Samaria said to Him, "How is it that You, being a Jew, ask a drink from me, a Samaritan woman?" For Jews have no dealings with Samaritans.

{10} Jesus answered and said to her, "If you knew the gift of God, and who it is who says to you, 'Give Me a drink,' you

would have asked Him, and He would have given you living water."

{11} The woman said to Him, "Sir, You have nothing to draw with, and the well is deep. Where then do You get that living water? {12} "Are You greater than our father Jacob, who gave us the well, and drank from it himself, as well as his sons and his livestock?"

{13} Jesus answered and said to her, "Whoever drinks of this water will thirst again, {14} "but whoever drinks of the water that I shall give him will never thirst. But the water that I shall give him will become in him a fountain of water springing up into everlasting life."

{15} The woman said to Him, "Sir, give me this water, that I may not thirst, nor come here to draw."

{16} Jesus said to her, "Go, call your husband, and come here."

{17} The woman answered and said, "I have no husband."

Jesus said to her, "You have well said, 'I have no husband,' {18} "for you



have had five husbands, and the one whom you now have is not your husband; in that you spoke truly."

{19} The woman said to Him, "Sir, I perceive that You are a prophet. {20} "Our fathers worshiped on this mountain, and you Jews say that in Jerusalem is the place where one ought to worship."

{21} Jesus said to her, "Woman, believe Me, the hour is coming when you will neither on this mountain, nor in Jerusalem, worship the Father. {22} "You worship what you do not know; we know what we worship, for salvation is of the Jews. {23} "But the hour is coming, and now is, when the true worshipers will worship the Father in spirit and truth; for the Father is seeking such to worship Him. {24} "God is Spirit, and those who worship Him must worship in spirit and truth."

{25} The woman said to Him, "I know that Messiah is coming" (who is called Christ). "When He comes, He will tell us all things."

{26} Jesus said to her, "I who speak to you am He."

{27} And at this point His disciples came, and they marveled that He talked with a woman; yet no one said, "What do You seek?" or, "Why are You talking with her?"

{28} The woman then left her waterpot, went her way into the city, and said to the men, {29} "Come, see a Man who told me all things that I ever did. Could this be the Christ?" {30} Then they went out of the city and came to Him.

{31} In the meantime His disciples urged Him, saying, "Rabbi, eat." {32} But He said to them, "I have food to eat of which you do not know."

{33} Therefore the disciples said to one another, "Has anyone brought Him anything to eat?"

{34} Jesus said to them, "My food is to do the will of Him who sent Me, and to finish His work. {35} "Do you not say, 'There

are still four months and then comes the harvest'? Behold, I say to you, lift up your eyes and look at the fields, for they are already white for harvest! {36} "And he who reaps receives wages, and gathers fruit for eternal life, that both he who sows and he who reaps may rejoice together. {37} "For in this the saying is true: 'One sows and another reaps.' {38} "I sent you to reap that for which you have not labored; others have labored, and you have entered into their labors."

{39} And many of the Samaritans of that city believed in Him because of the word of the woman who testified, "He told me all that I ever did."

{40} So when the Samaritans had come to Him, they urged Him to stay with them; and He stayed there two days. {41} And many more believed because of His own word.

{42} Then they said to the woman, "Now we believe, not because of what you said, for we ourselves have heard Him and we know that this is indeed the Christ, the Savior of the world."

{43} Now after the two days He departed from there and went to Galilee.

**Outer Aim - Jesus came to seek and to save all sinners, including the Samaritan woman and the other Samaritans.**

### What the Story Tells Us - Answer the questions.

1. Why did the Samaritan woman think it was strange that Jesus asked her for a drink of water?
2. Explain what Jesus meant by "living water."
3. Jesus asked the woman to call her husband. Why did she answer, "I have no husband?"
4. Why did Jesus ask her that question since He knew the answer?
5. The disciples were concerned that Jesus needed to eat. What did Jesus say was His food? (verse 34)
6. What convinced the Samaritans to believe in Jesus?

### What God's Word Tells Us - Answer the following.

1. After the Samaritan woman learned about Jesus, she couldn't keep it to herself. She wanted to share this good news with others. What are some ways you can reach out to others? List three.
  - a.
  - b.
  - c.
2. Samaritans and Jews were enemies at the time of our story. That could have been a barrier to Jesus and the woman but Jesus didn't let it stop Him. Can you think of any possible barriers today that might prevent you from sharing the Gospel with others?
  - a.
  - b.
3. Unscramble this Bible passage and print it on the line below.

**to man come Son was save has For the which lost seek and to of that**

---

(hint: Luke 19:10)

**Inner Aim - Jesus came to seek and to save all sinners, including me.**

## Passages

John 4:14 - "But whoever drinks of the water that I shall give him will never thirst. But the water that I shall give him will become in him a fountain of water springing up into everlasting life."

Luke 10:2 - Then He said to them, "The harvest truly is great, but the laborers are few; therefore pray the Lord of the harvest to send out laborers into His harvest."

## Hymn - TLH #277

I heard the voice of Jesus say,  
"Come unto Me and rest;  
Lay down thou weary one, lay down  
Thy head upon My breast."  
I came to Jesus as I was,  
Weary and worn and sad;  
I found in Him a resting place,  
And He has made me glad.

I heard the voice of Jesus say,  
"Behold, I freely give  
The living water; thirsty one,  
Stoop down and drink and live."  
I came to Jesus, and I drank  
Of that life-giving stream.  
My thirst was quenched, my soul revived,  
And now I live in Him.

I heard the voice of Jesus say, "I am this dark world's Light.  
Look unto Me; thy morn shall rise and all thy day be bright."  
I looked to Jesus, and I found in Him my Star, my Sun;  
And in that Light of Life I'll walk till trav'ling days are done.

## Prayer

Dear Jesus,

You shared the precious news of Your Gospel with the Samaritan woman. Help me to share Your saving Word with everyone I meet, so that they too will know about the "living water". Make me a willing laborer to gather in Your harvest. Thank You, Lord, for Your great love and mercy. Amen.

## Jesus Heals the Man at Bethesda

John 5

What is Jesus doing in this picture?  
Why do you think that He is doing this?

### Prayer

Dear Jesus, You are able to help us when no one else can. You have revealed Yourself as Lord over sickness and disease. According to Your will, help us when we are sick. You have revealed Yourself through the Bible. Help us learn more about You as we search the Scriptures for there we will find You. Amen.



### The Story - John 5:1-15 text, 16-47 summarized

After this there was a feast of the Jews, and Jesus went up to Jerusalem. {2} Now there is in Jerusalem by the Sheep Gate a pool, which is called in Hebrew, Bethesda, having five porches. {3} In these lay a great multitude of sick people, blind, lame, paralyzed, waiting for the moving of the water. {4} For an angel went down at a certain time into the pool and stirred up the water; then whoever stepped in first, after the stirring of the water, was made well of whatever disease he had.

{5} Now a certain man was there who had an infirmity thirty-eight years. {6} When Jesus saw him lying there, and knew that he already had been in that condition a long time, He said to him, "Do you want to be made well?"

{7} The sick man answered Him, "Sir, I have no man to put me into the pool when the water is stirred up; but while I am coming, another steps down before me."

{8} Jesus said to him, "Rise, take up your bed and walk." {9} And immediately the man was made well, took up his bed, and walked. And that day was the Sabbath.

{10} The Jews therefore said to him who was cured, "It is the Sabbath; it is not lawful for you to carry your bed."

{11} He answered them, "He who made me well said to me, 'Take up your bed and walk.'"

{12} Then they asked him, "Who is the Man who said to you, 'Take up your bed and walk'?" {13} But the one who was





healed did not know who it was, for Jesus had withdrawn, a multitude being in that place.

{14} Afterward Jesus found him in the temple, and said to him, "See, you have been made well. Sin no more, lest a worse thing come upon you." {15} The man departed and told the Jews that it was Jesus who had made him well.

When they heard this they began to persecute Jesus and planned to kill Him because they thought that by healing the man on the Sabbath He had intentionally broken the Sabbath laws.

Jesus responded by saying, "My Father has been working until now, and I have been working." This only made the Jews even more angry because now they thought that He was speaking blasphemy; He was making Himself equal to God.

Jesus continued by saying that the way to achieve eternal life is by going through God's Son. If someone rejects God's Son as the way to

achieve salvation, then they are turning their back on the only chance they have to be free of sin.

Jesus then pointed out some of the ways that people should be able to recognize that He is the Messiah. First of all, John the Baptist went before Him preaching about Jesus' coming.

Secondly, Jesus said that there are many prophecies in the Old Testament that point to Him. The miracles that Jesus performed pointed to the fact that He is the Son of God. Finally, Jesus said to the Jews that if they really believed what Moses had said, they would believe in Him because even Moses wrote about Him

Jesus is able to take care of not only man's physical weaknesses, but also his spiritual disease. Because of man's faith in Jesus, his sins are forgiven. Jesus explained this very thing to the Jews when they came to Him they rejected Jesus as their only way of salvation from sin.

### What God's Word Tells Us - Fill in the blank using the words in the box.

believe	disease	heaven	miracle	sickness
casually	eventually	Jesus	react	sin
claimed	faith	kill	Scripture	testifies
dig	healed	leaders	search	

Jesus h\_\_\_\_\_ the sick man by His divine power. Disease is a result of s\_\_\_\_\_. Even those people Jesus healed e\_\_\_\_\_ died. The final healing from d\_\_\_\_\_ will not take place until we are with Jesus in h\_\_\_\_\_.

J\_\_\_\_\_ heals us too. However He does not heal all diseases nor does He always do so with a m\_\_\_\_\_ like He did at the pool. Even a s\_\_\_\_\_ has a purpose in strengthening our f\_\_\_\_\_ and bringing us

closer to Jesus.

The Jewish l\_\_\_\_\_ rejected Jesus and even wanted to k\_\_\_\_\_  
 Him, not because He healed on the Sabbath Day, but because Jesus c\_\_\_\_\_  
 to be the Son of God. (John 5:18) People today also r\_\_\_\_\_ strongly to Jesus'  
 claim to be the Son of God.

Jesus is revealed in the S\_\_\_\_\_. The Old Testament t\_\_\_\_\_  
 concerning Him. Jesus encourages us to s\_\_\_\_\_ the Scriptures. We are not  
 to c\_\_\_\_\_ read the Bible just on Sundays. We are to d\_\_\_\_\_ into the Bible  
 daily. If someone does not b\_\_\_\_\_ the words of God in the Bible, he will not  
 believe Jesus.

**What the Story Tells Us** - Fill in the  
 Crossword Puzzle using the words in the  
 box.

Jesus	Jerusalem
Sabbath	angel
Bethesda	Jews
infirmities	bed

**Across**

- Jesus told the man to pick up his \_\_\_\_.
- \_\_\_\_\_ healed the man.
- This took place in \_\_\_\_\_.
- An \_\_\_ stirred up the water.

**Down**

- The name of the pool.
- The man was healed of his \_\_\_\_.
- The \_\_\_ scolded the man for carrying  
 his bed.

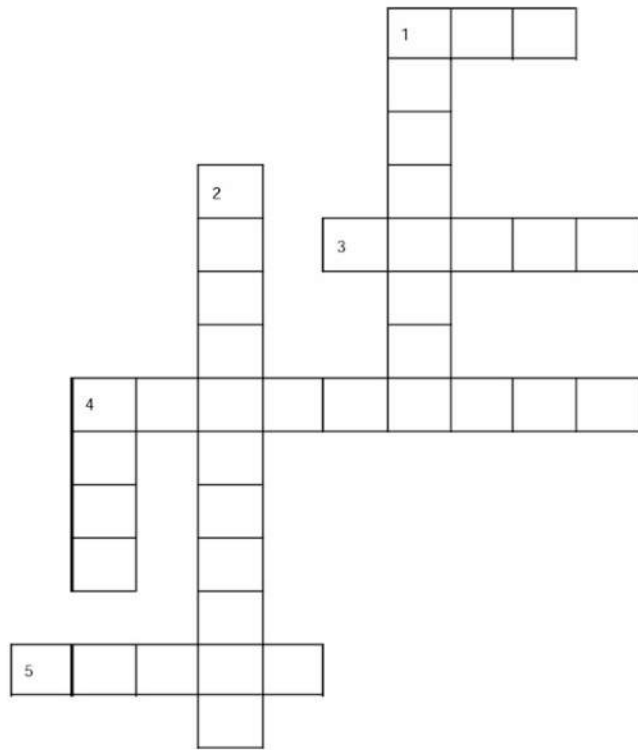

**Outer Aim - Jesus took away the man's sickness and revealed Himself as the Son of God.**

## Passages

2 Timothy 3:15-16 - And that from childhood you have known the Holy Scriptures, which are able to make you wise for salvation through faith which is in Christ Jesus.

All Scripture is given by inspiration of God, and is profitable for doctrine, for reproof, for correction, for instruction in righteousness.

John 5:39 - You search the Scriptures, for in them you think you have eternal life; and these are they which testify of Me.

**Inner Aim - Jesus takes away my sins and reveals Himself through the Holy Scriptures.**

**Hymn** - TLH #290 v. 1, 3, 4

We have a sure prophetic Word  
By inspiration of the Lord;  
And tho' assailed on ev'ry hand,  
Jehovah's Word shall ever stand.

Lo, what the Word in times of old  
Of future days and deeds foretold  
Is all fulfilled while ages roll,  
As traced on the prophetic scroll.

Abiding, steadfast, firm, and sure  
The teachings of the Word endure.  
Blest he who trusts this steadfast Word;  
His anchor holds in Christ, the Lord.

## Prayer

Dear Lord,  
Thank You for allowing us to gather together in order to study Your Word. Thank You for this reminder that You will always take away our infirmities, whether by healing us or by taking us to be with You in heaven where there will be no more sickness or death. Let not our will but Yours be done. Amen.

## Jesus Heals the Paralyzed Man

Mark 2:1-12

How does it feel when you are sick or have an injury?

What are some things that make you feel better?

### Prayer

Dear Father in heaven,

Send Your Holy Spirit into our hearts so we will gladly hear and study Your Word. Help us today as we learn how Jesus, Your Son, has power to forgive sins and help in all our needs. We pray in Jesus' name. Amen.

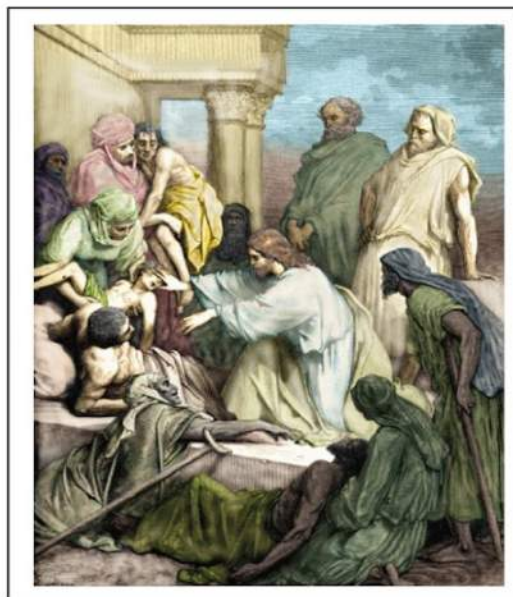

### The Story - Mark 2:1-12

And again He entered Capernaum after some days, and it was heard that He was in the house. {2} Immediately many gathered together, so that there was no longer room to receive them, not even near the door. And He preached the word to them.

{3} Then they came to Him, bringing a paralytic who was carried by four men. {4} And when they could not come near Him because of the crowd, they uncovered the roof where He was. So when they had broken through, they let down the bed on which the paralytic was lying.

{5} When Jesus saw their faith, He said to the paralytic, "Son, your sins are

forgiven you."

{6} And some of the scribes were sitting there and reasoning in their hearts, {7} "Why does this Man speak blasphemies like this? Who can forgive sins but God alone?"

{8} But immediately, when Jesus perceived in His spirit that they reasoned thus within themselves, He said to them, "Why do you reason about these things in your hearts? {9} "Which is easier, to say to the paralytic, 'Your sins are forgiven you,' or to say, 'Arise, take up your bed and walk'? {10} "But that you may know that the Son of Man has power on earth to forgive sins"; He said to the paralytic, {11} "I say



to you, arise, take up your bed, and go to your house."

{12} Immediately he arose, took up the bed, and went out in the

presence of them all, so that all were amazed and glorified God, saying, "We never saw anything like this!"

---

**Outer Aim - Jesus heals a paralyzed man.**

---

**What the Story Tells Us** - Fill in the blanks with words from Mark 2:1-12

1. Jesus entered the city of \_\_\_\_\_.
2. Jesus \_\_\_\_\_ the Word to a large crowd of people.
3. Four men carried a paralyzed man to Jesus to be \_\_\_\_\_.
4. When Jesus saw their \_\_\_\_\_, He said to the paralyzed man, "Son your sins are \_\_\_\_\_ you."
5. The \_\_\_\_\_ thought Jesus was speaking blasphemies.
6. Jesus told them that the \_\_\_\_\_ \_\_\_\_\_ \_\_\_\_\_ has power to forgive sins.
7. When Jesus healed the paralyzed man he was immediately able to \_\_\_\_\_.
8. The people were amazed and \_\_\_\_\_ God.

**What God Tells Us** - Cross out the incorrect answers only. In some sentences, both answers are correct.

1. Jesus knows that the most important thing is (to make our bodies well) (to forgive our sins).
2. God heals us by using (doctors) (medicines).
3. God wants us to (bring our problems to Him) (only ask for help with major problems).
4. Jesus proved He is true God by (His power to forgive sins) (His power to make the paralyzed man well).
5. Read John 20:23 Every Christian (has) (does not have) the power to announce or withhold the forgiveness of sins.
6. Read John 20:23 As a Christian we too can (forgive the sins of the penitent sinner) (retain the sins of the impenitent).

---

**Inner Aim - Jesus has the power and authority to forgive sins.**

---

**Passages** - Read each passage.

1 Peter 5:7 Casting all your care upon Him; for He cares for you.

1 John 1:7 The blood of Jesus Christ His Son cleanses us from all sin.

Matthew 11:28-29 "Come to Me, all you who labor and are heavy laden, and I will give you rest. Take My yoke upon you and learn from Me, for I am gentle and lowly in heart, and you will find rest for your souls."

## Hymn - TLH 515 v. 1, 2, 4, 6

O Thou from whom all goodness flows,  
I lift my heart to Thee;  
In all my sorrows, conflicts, woes,  
Dear Lord, remember me.

When on my poor and burdened heart  
My sins lie heavily,  
Thy pardon speak, new peace impart;  
Dear Lord, remember me.

If worn with pain, disease, or grief  
This feeble body be,  
Grant patience, rest, and kind relief;  
Dear Lord, remember me.

And when before Thy throne I stand  
And lift my soul to Thee,  
Then with the saints at Thy right hand,  
dear Lord, remember me.

**Your Turn** - Use ideas from the story and hymn to write a prayer you could use for yourself or someone else who is sick.

## Prayer

Dear Lord, Jesus,

You show us through Your Word today Your great power over sin and sicknesses. When our sins trouble us, draw us in faith to You for the forgiveness that You alone can give, so that we may find peace and joy through sins forgiven. When sickness comes upon us, give us a patient faith that continues to seek Your strength and healing through prayer. When we are healed, may Your name be glorified before those who doubt You. We pray, trusting in Your grace and mercy, Amen.

## Jesus Raises the Daughter of Jairus

Luke 8:40-56

Of what does this lily remind you?

Why is Easter such an important day for us?

Learn from our lesson how Jesus showed His power over even death itself.

**Prayer** - TLH 3 v. 1

Lord Jesus Christ, be present now,  
Our hearts in true devotion bow,  
Thy Spirit send with grace divine,  
And let Thy truth within us shine. Amen.

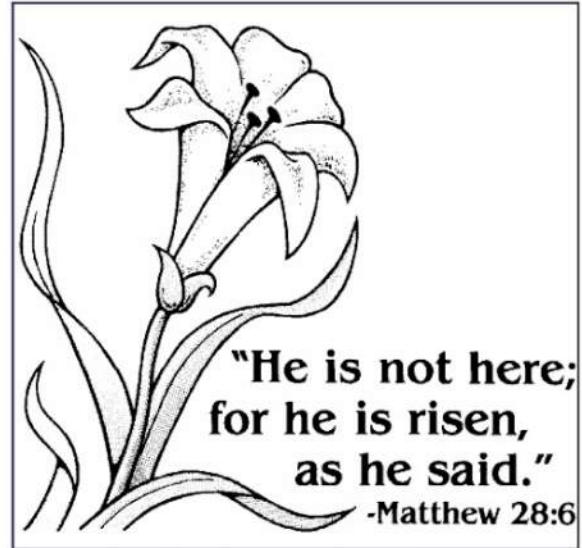

### Jesus Raises the Daughter of Jairus - Luke 8:40-56

So it was, when Jesus returned, that the multitude welcomed Him, for they were all waiting for Him. And behold, there came a man named Jairus, and he was a ruler of the synagogue. And he fell down at Jesus' feet and begged Him to come to his house, for he had an only daughter about twelve years of age, and she was dying.

But as He went, the multitudes

crowded around Him. Then a woman in the crowd who had been sick for twelve years, touched the hem of Jesus' garment hoping that He could help her. Immediately, she was healed. When Jesus asked who had touched Him, she fell at His feet and told Him why she had touched Him. Then Jesus said, "Daughter, be of good cheer; your faith has made you well. Go in peace."



While He was still speaking, someone came from the ruler of the synagogue's house, saying to him, "Your daughter is dead. Do not trouble the Teacher."

But when Jesus heard it, He answered him, saying, "Do not be afraid; only believe, and she will be made well."

When He came into the house, He permitted no one to go in except Peter, James, and John, and the father and mother of the girl. Now all wept and mourned for her; but He said, "Do not weep; she is not dead, but sleeping."

And they ridiculed Him, knowing that she was dead. But He put them all outside, took her by the hand and called, saying, "Little girl, arise."

Then her spirit returned, and she arose immediately. And He commanded that she be given something to eat. And her parents were astonished, but He charged them to tell no one what had happened.

### **Outer Aim - Jesus made Jairus' daughter alive.**

**Recalling Details** Fill in the blanks with the correct word.

1. Jairus was the \_\_\_\_\_ of the synagogue.
2. Jairus asked \_\_\_\_\_ to come to his house.
3. Jairus's \_\_\_\_\_ was very sick.
4. A messenger said it was too \_\_\_\_\_ for Jesus to come.
5. At Jairus's house, many people were \_\_\_\_\_.
6. Jesus said, "The little girl is \_\_\_\_\_."
7. Jesus took the girl's parent's and \_\_\_\_\_ disciples into the house.
8. Jesus made the little girl \_\_\_\_\_ by the power of His Word.

**Do You Remember?** Put "Yes" or "No" in the blank.

1. \_\_\_\_ Jairus had only one child.
2. \_\_\_\_ Jairus wasn't sure that Jesus could help him.
3. \_\_\_\_ The messenger thought it was too late for Jesus to help.
4. \_\_\_\_ Jesus told the woman that He had made her well.
5. \_\_\_\_ People were crying because the girl had died.

**Discussion Questions**

1. How was Jesus received when He returned to the city of Capernaum?
2. Why was the woman in the story healed when she touched Jesus' garment?
3. What does this section of Scripture tell us about the power of Jesus?
4. Which two people in the story showed that they believed in Jesus? How?
5. Why do you think that Jesus told the parents to give the girl something to eat after she was alive?
6. Why did Jesus refer to death as a "sleep"?
7. What does this story tell us about what we should do when we need help?
8. How can you comfort someone who is sick or has lost a loved one ?

**Inner Aim - We too will be made alive and will live forever in heaven.**

## Hymn Study WS 785 v. 3, 4

Neither life nor death shall ever  
From the Lord His children sever;  
Unto them His grace He showeth,  
And their sorrows all He knoweth.

Though He giveth or He taketh,  
God His children ne'er forsaketh;  
His the loving purpose solely  
To preserve them pure and holy.

## Memory Passage

John 11:25-26 - Jesus said to her, "I am the resurrection and the life. He who believes in Me, though he may die, he shall live. And whoever lives and believes in Me shall never die. Do you believe this?"

Do you believe this message?

## Prayer

Dear Lord Jesus,

Teach us to come to You with all our needs just like Jairus did. Give us a faith which trusts that You will take care of us in times of sickness. We know that because You died for us and rose again on Easter, we do not need to fear death. Help us to believe that our death will be just the beginning of everlasting life with You in Heaven. We thank You for conquering sin and death for us. Keep us faithful until death. Amen.

# The Centurion's Servant

Matthew 8:5-13; Luke 7:1-10

What religion are these children?

Are you a member of the Jewish religion?

If you are not a Jew, what are you?

Today we will hear about a faithful Gentile soldier.



## Prayer

Dear Father in Heaven,

Help us to learn from Your Holy Bible the lesson today.

Make our faith grow stronger through the study of that Word. Thank You for giving us faith to trust in Your Son, Jesus, for the forgiveness of sins. Amen.

## The Story - Matthew 8:5-13; Luke 7:1-10

Matthew 8: 5 - Now when Jesus had entered Capernaum, a centurion came to Him, pleading with Him, {6} saying, "Lord, my servant is lying at home paralyzed, dreadfully tormented."

{7} And Jesus said to him, "I will come and heal him."

{8} The centurion answered and said, "Lord, I am not worthy that You should come under my roof. But only speak a word, and my servant will be healed. {9} "For I also am a man under authority, having soldiers under me. And I say to this one, 'Go,' and he goes; and to another, 'Come,' and he comes; and to my servant, 'Do this,' and he does it."

{10} When Jesus heard it, He marveled, and said to those who followed, "Assuredly, I say to you, I have not found such great faith, not even in Israel! {11} "And I say to you that many will come from east and west, and sit down with Abraham, Isaac, and Jacob in the kingdom of heaven. {12} "But the sons of the kingdom will be cast out into outer darkness. There will be weeping and gnashing of teeth." {13} Then Jesus said to the centurion, "Go your way; and as you have believed, so let it be done for you." And his servant was healed that same hour.

Luke 7:1 - Now when He concluded



all His sayings in the hearing of the people, He entered Capernaum. {2} And a certain centurion's servant, who was dear to him, was sick and ready to die. {3} So when he heard about Jesus, he sent elders of the Jews to Him, pleading with Him to come and heal his servant. {4} And when they came to Jesus, they begged Him earnestly, saying that the one for whom He should do this was deserving, {5} "for he loves our nation, and has built us a synagogue."

{6} Then Jesus went with them. And when He was already not far from the house, the centurion sent friends to Him, saying to Him, "Lord, do not trouble Yourself, for I am not

worthy that You should enter under my roof. {7} "Therefore I did not even think myself worthy to come to You. But say the word, and my servant will be healed. {8} "For I also am a man placed under authority, having soldiers under me. And I say to one, 'Go,' and he goes; and to another, 'Come,' and he comes; and to my servant, 'Do this,' and he does it."

{9} When Jesus heard these things, He marveled at him, and turned around and said to the crowd that followed Him, "I say to you, I have not found such great faith, not even in Israel!" {10} And those who were sent, returning to the house, found the servant well who had been sick.

---

### **Outer Aim Jesus heals a Centurion's servant.**

---

**Review** - Use the story to answer the following questions.

1. What city did Jesus enter?
2. What was the centurion's request?
3. Why was this Gentile liked by the Jews of the city?
4. Why did the centurion not want Jesus to come into his home?
5. How did Jesus describe the faith of this centurion?
6. What happened to the servant?

**Word Search** - Find the words from the Word Box in the puzzle below.

GENTILE SYNAGOGUE	CAPERNAUM WORTHY	HEALED SERVANT	FAITH CENTURION	JEWS PARALYZED
----------------------	---------------------	-------------------	--------------------	-------------------

C A P E R N A U M P  
 E D A K S W G H Y E  
 N V R H E A L E D S  
 T Y A P R V O Y L K  
 U P L E V X P P K N  
 R S Y N A G O G U E  
 I Q Z O N E B L S W  
 O W E P T N F M E O  
 N E D R X T E E C R  
 P I P F A I T H G T  
 O L M O T L E R L H  
 B C O S J E W S Q Y

**Bible Passages** - Use the Bible passages to do the activity below.

*Psalm 50:15 "Call upon me in the day of trouble; I will deliver you,  
and you shall glorify Me."*

Circle the words that tell what God promises to do for us when we need help.  
Underline the words that tell how will we show our thanks.

*Psalms 130:3-5 "If You, LORD, should mark iniquities, O Lord, who could stand?  
But there is forgiveness with You, that You may be feared.  
I wait for the LORD, my soul waits, and in His word I do hope."*

Underline the word that means sins. Circle the word for what Christ has done for us. Put a box around what helps us wait for the LORD.

---

**Inner Aim God gives faith to trust in Him.**

---

**What God's Word Tells Us** - Use the words in the box twice. Use them once to fill in the blanks about the centurion and then use the words to fill in the blanks about Christians.

<b>confident</b>	<b>love</b>	<b>humble</b>
------------------	-------------	---------------

How the centurion showed his faith...

... \_\_\_\_\_ for his servant.  
... \_\_\_\_\_ before Jesus.  
... \_\_\_\_\_ of Jesus' power  
to heal.

How a Christian shows his/her faith...

... \_\_\_\_\_ for our neighbor.  
... \_\_\_\_\_ before Jesus.  
... \_\_\_\_\_ of Jesus' power  
to save us.

**Hymn** TLH #518 v. 1, 7

If thou but suffer God to guide thee  
And hope in Him thro' all thy ways,  
He'll give thee strength, whate'er betide thee,  
And bear thee thro' the evil days.  
Who trusts in God's unchanging love  
Builds on the Rock that naught can move.

Sing, pray, and keep His ways unswerving,  
Perform thy duties faithfully,  
And trust His Word' though undeserving,  
Thou yet shalt find it true for thee.  
God never yet forsook in need  
The soul that trusted Him indeed.

**Prayer**

Jesus Christ my Savior,

Thank You for bringing Your Word to us and to people of every nation. Help us to trust Your Word with humble and courageous hearts that we may lay hold of all Your precious promises. We know that You have the power and the love to do all that You have promised. When we call upon You, we know that You will answer in a way that is best for all. Because of what Jesus has done for us, we know we will be saved. We come to You, Jesus, in Whom we trust!  
Amen!

## The Young Man of Nain

Luke 7:11-17

When might a person receive a basket of flowers like this?

Why do people send flowers to others?

How do flowers make you feel?



### Prayer

Dear Father in heaven,

We thank You for sending Your son, Jesus Christ, into the world to suffer and die for our sins. We know that You have given Jesus all power in heaven and on earth. Help us to remember that Jesus is able to keep all harm and danger away from us. Give us trusting hearts that cling to Jesus' promise to be with us always, especially in the hour of our death, after which we will wake to be with You forever. In Jesus' name. Amen.

### The Young Man of Nain - Luke 7:11-17

Now it happened, the day after, that He went into a city called Nain; and many of His disciples went with Him, and a large crowd. (12) And when He came near the gate of the city, behold, a dead man was being carried out, the only son of his mother; and she was a widow. And a large crowd from the city was with her.

(13) When the Lord saw her, He had compassion on her and said to her, "Do not weep." (14) Then He came and touched the open coffin,

and those who carried him stood still. And He said, "Young man, I say to you, arise." (15) So he who was dead sat up and began to speak. And He presented him to his mother.

(16) Then fear came upon all, and they glorified God, saying, "A great prophet has risen up among us"; and, "God has visited His people."

(17) And this report about Him went throughout all Judea and all the surrounding region.





**What the Story Tells Us** - Put the correct answer from the story into the blank.

1. Jesus went into a city called \_\_\_\_\_.
2. At the gate he met a \_\_\_\_\_ whose only son had died.
3. When the Lord saw her, He had \_\_\_\_\_ on her.
4. Jesus said, "Young man, I say to you, \_\_\_\_\_."
5. He who was dead \_\_\_\_\_ up and began to \_\_\_\_\_.
6. Then the people \_\_\_\_\_ God.
7. A great \_\_\_\_\_ has risen up among us!

---

### **Outer Aim**

**Jesus raises the young man of Nain from the dead.**

---

**What God Tells Us** - Mark each as (T)true or (F)alse. Change the false statements to make them true.

- \_\_\_ 1. We go to funerals to show support to the living family members.
- \_\_\_ 2. Christians should never feel sad when a relative dies.
- \_\_\_ 3. God's Word can be used to comfort someone who has had a friend or family member die.
- \_\_\_ 4. Jesus has promised to hear us whenever we ask for His help.
- \_\_\_ 5. We can be sure that we will be with Jesus when we die.
- \_\_\_ 6. Since Jesus is God, He can't understand our problems and troubles.
- \_\_\_ 7. When we are sick we ask Jesus to make us better, if it is His will.

## Passages

O Death, where is your sting? O Hades, where is your victory? The sting of death is sin, and the strength of sin is the law. But thanks be to God, who gives us the victory through our Lord Jesus Christ. 1 Corinthians 15:55-57

And God will wipe away every tear from their eyes; there shall be no more death, nor sorrow, nor crying. There shall be no more pain, for the former things have passed away. Revelation 21:4

And do not fear those who kill the body but cannot kill the soul. But rather fear Him who is able to destroy both soul and body in hell. Matthew 10:28

Jesus said to her, "I am the resurrection and the life. He who believes in Me, though he may die, he shall live. And whoever lives and believes in Me shall never die. Do you believe this?" John 11:25-26

---

## Inner Aim

**God knows all of our troubles and promises to help us through all of them, even death.**

---

## Hymn - TLH 193 1,4,5

"Christ the Lord is ris'n today,"  
Sons of men and angels say.  
Raise your joys and triumphs high;  
Sing, ye heav'ns, and, earth, reply.

Lives again our glorious King;  
Where, O Death, is now thy sting?  
Once He died our souls to save;  
Where thy victory, O Grave?

Soar we now where Christ has led,  
Following our exalted Head.  
Made like Him, like Him we rise;  
Ours the cross, the grave, the skies.

Which stanzas of Hymn 193 do you think would be good to use to comfort a family that has experienced the death of a family member or close friend? Explain why you chose those stanzas.

**Your Turn** - Use ideas from the story, the passages, and the hymn you read today to complete the following activities.

A Christian relative of your good friend has died. What words of comfort could you give to your friend?

You or a family member is very ill. Write a prayer asking the Lord for help.

## **Prayer**

Lord, I feel great comfort when I remember that You are in control and will take care of my family and me. Help me to remember Your promise to care for me even in the time of death. In Your name we pray. Amen.

## The Parable of the Sower and the Seed

Matthew 13:1-9, 18-23

This stained glass window shows "The Sower and the Seed".

Do you remember that parable?

Why would it be a good picture for display in a church?

### Prayer

Dear Lord,

We know that we are sinful people. Help us to be good listeners today when we read the story or parable You told about the sower and the seed. Please do not let anything distract us while we learn about You. Thank You for sending Your Son to earth so we can go to heaven. Amen.



### The Story - Matthew 13:1-9, 18-23

On the same day Jesus went out of the house and sat by the sea. {2} And great multitudes were gathered together to Him, so that He got into a boat and sat; and the whole multitude stood on the shore.

{3} Then He spoke many things to them in parables, saying: "Behold, a sower went out to sow. {4} "And as he sowed, some seed fell by the wayside; and the birds came and devoured them. {5} "Some fell on stony places, where they did not have much earth; and they immediately sprang up because they had no depth of earth.

{6} "But when the sun was up they were scorched, and because

they had no root they withered away.

{7} "And some fell among thorns, and the thorns sprang up and choked them.

{8} "But others fell on good ground and yielded a crop: some a hundredfold, some sixty, some thirty. {9} "He who has ears to hear, let him hear!"

(18) "Therefore hear the parable of the sower: {19} "When anyone hears the word of the kingdom, and does not understand it, then the wicked one comes and snatches away what was sown in his heart. This is he who received seed by the wayside.



{20} "But he who received the seed on stony places, this is he who hears the word and immediately receives it with joy; {21} "yet he has no root in himself, but endures only for a while. For when tribulation or persecution arises because of the word, immediately he stumbles.

{22} "Now he who received seed among the thorns is he who

hears the word, and the cares of this world and the deceitfulness of riches choke the word, and he becomes unfruitful.

{23} "But he who received seed on the good ground is he who hears the word and understands it, who indeed bears fruit and produces: some a hundredfold, some sixty, some thirty."

**What the Story Tells Us** - Retell the story by drawing a picture to show each of the types of ground and the plant life that lives there.

1. by the wayside	2. on the stony ground
3. among the thorns	4. on the good ground

**Outer Aim** - Jesus told a parable that describes the enemies working against the Word of God.

**What God's Word Tells Us** - Match the earthly pictures with the heavenly meaning of this parable as explained by Jesus.

- |   |   |
|---|---|
| 1. ____ The seed refers to ...              | A. ... the one who receives the word but faith is choked out by the world.                            |
| 2. ____ The birds represent ...             | B. ... the ones who hear and understand the word and bear fruit.                                      |
| 3. ____ The seed at the wayside is ...      | C. ... the wicked one.  |
| 4. ____ The seed on the stony ground is ... | D. ... the word of the kingdom of heaven.   |
| 5. ____ The seed among the thorns is ...    | E. ... the ones that hear and don't understand it.  |
| 6. ____ The seed on the good ground is ...  | F. ... the ones who first receive the word with joy but when troubles arise they immediately stumble. |

**Inner Aim** - Jesus has taken away my sins and reveals Himself through the Holy Scriptures.

**Passages** - Look up these passages in the Bible, fill in the blanks and discuss the questions.

Romans 10:17 So then \_\_\_\_\_ comes by \_\_\_\_\_, and \_\_\_\_\_  
by the \_\_\_\_\_.

*How do we receive faith according to this passage?*

1 Samuel 3:9 ... 'Speak, \_\_\_\_\_, for \_\_\_\_\_  
\_\_\_\_\_."

*Who gives us our instructions for life according to this passage?*

John 8:31-32 Then Jesus said to those Jews who believed Him, "If you \_\_\_\_\_ in My \_\_\_\_\_, you are My \_\_\_\_\_ indeed. {32} "And you shall \_\_\_\_\_ the \_\_\_\_\_, and the \_\_\_\_\_ shall make you \_\_\_\_\_."

*What command does God give us in this passage?*

*What will the "truth" which Jesus speaks of do for us?*

### **Hymn** - TLH #49

Almighty God, Thy Word is cast  
Like seed into the ground;  
Now let the dew of heav'n descend  
And righteous fruits abound.

Let not the foe of Christ and man  
This holy seed remove,  
But give it root in ev'ry heart  
To bring forth fruits of love.

Let not the world's deceitful cares  
The rising plant destroy,  
But let it yield a hundredfold  
The fruits of peace and joy.

Oft as the precious seed is sown,  
Thy quickening grace bestow  
That all whose souls the truth receive  
Its saving power may know.

### **Prayer**

Dear Father in Heaven,

We ask You for a strong faith which grows in a heart filled with Your love. Thank You for sending Jesus to forgive our sins and for sending the Holy Spirit into our hearts through Your Word. Please help us spread the Word of forgiveness and salvation to others. In Jesus' name we ask. Amen.

## Jesus Feeds the Five Thousand

Matthew 14:13-21; Mark 6:34-44; Luke 9:10-17; John 6:1-15



Jesus and His disciples are giving food to this crowd in the picture.

With what else did Jesus feed this crowd that day?

### Prayer

We thank You, Heavenly Father, for sending Jesus, Your Son, to be our Savior. We praise You that both the Person and teachings of Jesus have been confirmed for us by the miracles He performed. Help us, we pray, always to trust in Him for our salvation, and for all our needs. Strengthen our faith by the working of the Holy Spirit as we study Your Holy Word, Amen.

### The Story - John 6:1-15

(1) After these things Jesus went over the Sea of Galilee, which is the Sea of Tiberias. (2) Then a great multitude followed Him, because they saw His signs which He performed on those who were diseased. (3) And Jesus went up on the mountain, and there He sat with His disciples. (4) Now the Passover, a feast of the Jews, was near.

(5) Then Jesus lifted up His eyes, and seeing a great multitude coming toward Him, He said to

Philip, "Where shall we buy bread, that these may eat?" (6) But this He said to test him, for He Himself knew what He would do.

(7) Philip answered Him, "Two hundred denarii worth of bread is not sufficient for them, that every one of them may have a little."

(8) One of His disciples, Andrew, Simon Peter's brother, said to Him, (9) "There is a lad here who has five barley loaves and two small fish, but what are they among so many?"





(10) Then Jesus said, "Make the people sit down." Now there was much grass in the place. So the men sat down, in number about five thousand. (11) And Jesus took the loaves, and when He had given thanks He distributed them to the disciples, and the disciples to those sitting down; and likewise of the fish, as much as they wanted.

(12) So when they were filled, He said to His disciples, "Gather up the fragments that remain, so that nothing is lost." (13) Therefore they gathered them up, and filled twelve

baskets with the fragments of the five barley loaves which were left over by those who had eaten.

(14) Then those men, when they had seen the sign that Jesus did, said, "This is truly the Prophet who is to come into the world." (15) Therefore when Jesus perceived that they were about to come and take Him by force to make Him king, He departed again to the mountain by Himself alone.

---

**Outer Aim - Jesus showed his love and mercy to more than 5000 people by feeding them both body and soul.**

---

**What the Lesson Tells Us** - Supply short answers to the following questions.

1. Where did Jesus and His disciples go, in order to have a period of rest?
2. When Jesus and the disciples arrived there, what kept them from being able to rest?
3. How did Jesus test the faith of the disciples?
4. What miracle did Jesus perform in this place?

---

## Inner Aim God provides for our physical and spiritual needs

---

**What God Tells Us** - *Discuss* the following questions in class, based on the Bible story for today.

1. According to verse 2, what was the reason for the popularity of Jesus in Galilee?  
  
What application of this lesson about trusting in Jesus to meet all our needs can we make in our own lives?
2. If the primary purpose of the miracles Jesus performed was not to meet temporary, earthly needs, what was it? (John 20:30-31 is a key to understanding the purpose of miracles)
3. Jesus provided a test of faith for His disciples, by asking them how the crowds of people could be fed (vv. 5&6). He wanted them to recognize that although meeting this need was beyond human ability, they could simply turn to Him Whom they recognized to be the Messiah (cf. John 1:45), confidently looking to Him to supply any genuine need. In this connection, they might even have remembered the example of Mary, Jesus' mother, who at the wedding in Cana simply brought the need to Jesus, and left it to Him to do what was best. The disciples failed this test of faith.  
  
4. Although Jesus had only two fish and five loaves of barley bread, He was able to provide more than enough to satisfy 5,000 men. Afterwards, twelve baskets full of leftovers were gathered up. Why do you suppose these details are included in the inspired account? (hint: one possibility has to do with the principle of good stewardship of gifts, and another with the fact that some people claim that miracles are simply the result of people thinking something had happened, when it really didn't)
5. In verse 14, the people said of Jesus, "This is truly the Prophet who is to come into the world." This term showed that they saw Jesus as the Messiah. They even wanted to make Jesus their leader. However, there was a BIG problem with this. What was it?

## Passages

Jesus answered them, "... The works that I do in My Father's name, they bear witness of Me." John 10:25

"...the Son of Man did not come to be served, but to serve, and to give His life a ransom for many." Matthew 20:28

Oh, taste and see that the Lord is good; Blessed is the man who trusts in Him!  
Psalm 34:8

## Hymn - TLH#355

Thou art the Way; to Thee alone  
From sin and death we flee;  
And he who would the Father seek  
Must seek Him, Lord, by Thee.

Thou art the Life; the rending tomb  
Proclaims Thy conqu'ring arm;  
And those who put their trust in Thee  
Nor death nor hell shall harm.

Thou art the Truth; Thy Word alone  
True wisdom can impart;  
Thou only canst inform the mind  
And purify the heart.

Thou art the Way, the Truth, the Life;  
Grant us that Way to know,  
That Truth to keep, that Life to win,  
Whose joys eternal flow. Amen.

**Prayer** - Think of what this story reveals about Jesus, and compose a prayer that includes thanks for something, and a request for something, based on this lesson. This may be a group exercise.

## Jesus Walking on the Sea

Matthew 14:22-33; Mark 6:45-52; John 6:15-21

Have you ever lied?

Do people sometimes doubt what you tell them?

Jesus never lies. We can always trust in and rely on Him.

### Prayer

The Lord's Prayer

### The Story

Therefore when Jesus perceived that they were about to come and take Him by force to make Him king, He immediately made His disciples get into the boat and go before Him to the other side, to Bethsaida. Jesus sent the multitudes away, and departed again to the mountain by Himself to pray.

Now when evening came, the boat was in the middle of the sea; and He was alone on the land. The boat was being tossed by the waves, for the wind was contrary. Jesus saw them straining at rowing, for the wind was against them.

Now about the fourth watch of the night He came to them, walking on the sea, and would have passed them



by. They had rowed about three or four miles when they saw Jesus walking on the sea drawing near to the boat. When they saw Him, they supposed it was a ghost, and were troubled, saying, "It is a ghost!" And they cried out for fear. But immediately Jesus spoke to them, saying, "Be of good cheer! It is I; do not be afraid."

And Peter answered Him and said, "Lord, if it is You, command me to come to You on the water."

So He said, "Come." And when Peter had come down out of the boat, he walked on the water to go to Jesus. But when he saw that the wind was boisterous, he was afraid;

and beginning to sink he cried out, saying, "Lord, save me!"

And immediately Jesus stretched out His hand and caught him, and said to him, "O you of little faith, why did you doubt?"

The disciples willingly received Him into the boat, and immediately the wind ceased. Immediately the boat was at the land where they were going.

And they were greatly amazed in themselves beyond measure, and marveled. Then those who were in the boat came and worshiped Him, saying, "Truly You are the Son of God." For they had not understood about the loaves, because their heart was hardened.

---

### Outer Aim

**Jesus walked on water to help His disciples.**

---

**What the Lesson Tells Us** - Fill in the blanks with the best answer from the lesson.

1. The people wanted to make Jesus into a \_\_\_\_\_.
2. Jesus was \_\_\_\_\_ on the land.
3. About the \_\_\_\_\_ watch of the night Jesus came to them walking on the sea.
4. The disciples thought Jesus was a \_\_\_\_\_.
5. \_\_\_\_\_, one of the disciples, walked on the water too.
6. Jesus said, "Oh, you of little \_\_\_\_\_, why did you doubt?"
7. After the miracle, the disciples said, "Truly You are the \_\_\_\_\_ \_\_\_\_\_ \_\_\_\_\_."

## What God Tells Us – Mark each as (T)rue or (F)alse.

- \_\_\_ 1. God sends us bad weather and troubles to punish us.
- \_\_\_ 2. We should show our trust in God by walking on water.
- \_\_\_ 3. We should always place our trust in God even if others make fun of us.
- \_\_\_ 4. Since God is our Father, we don't need to listen to our earthly parents.
- \_\_\_ 5. Doubting God is not always wrong.
- \_\_\_ 6. Because Jesus loves us, He will always do what is best for us.
- \_\_\_ 7. Worrying is a sin.

## Hymn - Look at Hymn 528 v. 1, 2. How does verse 2 fit this story?

If God Himself be for me,  
I may a host defy;  
For when I pray, before me  
My foes, confounded, fly.  
If Christ, my Head and Master,  
Befriend me from above,  
What foe or what disaster  
Can drive me from His love?

This I believe, yea, rather,  
Of this I make my boast,  
That God is my dear Father,  
The Friend who loves me most,  
And that, whate'er betide me,  
My Savior is at hand  
Thro' stormy seas to guide me  
And bring me safe to land.

## Passages

Call upon Me in the day of trouble; I will deliver you, and you shall glorify Me.  
Psalm 50:15

God is our refuge and strength, a very present help in trouble. Therefore we will not fear, even though the earth be removed, and though the mountains be carried into the midst of the sea; though its waters roar and be troubled, though the mountains shake with its swelling. Psalm 46:1-3

What then shall we say to these things? If God is for us, who can be against us? He who did not spare His own Son, but delivered Him up for us all, how shall He not with Him also freely give us all things? Romans 8:31-32

For I am persuaded that neither death nor life, nor angels nor principalities nor powers, nor things present nor things to come, nor height nor depth, nor any other created thing, shall be able to separate us from the love of God which is in Christ Jesus our Lord. Romans 8:38-39

---

### Inner Aim

**Believe in Jesus without a doubt.**

---

**Your Turn** - List the six miracles of Jesus in this story. Explain how these make you feel.

- 1.
- 2.
- 3.
- 4.
- 5.
- 6.

### Prayer

Lord Jesus,

I am happy to know that You care for me. I look at how You took care of the disciples on the boat so long ago. I know that You keep me safe too. Thank You for this and all things. Amen.

## The Woman of Canaan

Matthew 15:21-28; Mark 7:24-30

What is prayer?

Why do people pray?

### Prayer

Dear Father in Heaven. We pray You will send the Holy Spirit to us, so we will gladly hear and study Your Word. Help us as we learn to come to You in prayer and trust in You for everything. In Jesus name. Amen.



### The Story

(Matthew 15:21-28) Then Jesus went out from there and departed to the region of Tyre and Sidon. {22} And behold, a woman of Canaan came from that region and cried out to Him, saying, "Have mercy on me, O Lord, Son of David! My daughter is severely demon-possessed."

(Mark 7:26) The woman was a Greek, a Syro-Phoenician by birth, and she kept asking Him to cast the demon out of her daughter.

{23} But He answered her not a word. And His disciples came and urged Him, saying, "Send her away, for she cries out after us."

{24} But He answered and said, "I was not sent except to the lost sheep of the house of Israel." {25} Then she came and worshiped Him, saying, "Lord, help me!"

{26} But He answered and said, "It is not good to take the children's bread and throw it to the little dogs."

{27} And she said, "Yes, Lord, yet even the little dogs eat the crumbs which fall from their masters' table."

{28} Then Jesus answered and said to her, "O woman, great is your faith! Let it be to you as you desire." And her daughter was healed from that very hour.

---

### Outer Aim

**A Gentile woman persevered in seeking help from Jesus.**

---





**What the Story Tells Us** - Match by writing the correct letter.

- |                             |  |
|-----------------------------|--|
| 1. Jesus traveled to        | a. possessed by a devil                  |
| 2. A Gentile woman          | b. the region of Tyre and Sidon          |
| 3. Her daughter was         | c. came to Jesus in help                 |
| 4. The Gentile woman showed | d. her faith in Jesus                    |
| 5. At first Jesus           | e. He came to help only Israel.          |
| 6. Then Jesus said          | f. did not answer the woman              |
| 7. The woman continued      | g. over the devil and evil spirits       |
| 8. Jesus said the woman     | h. healed the daughter                   |
| 9. Then Jesus               | i. had great faith                       |
| 10. Jesus showed his power  | j. to pray even though Jesus didn't help |

---

**Inner Aim**

**Our faith looks expectantly to God for all of our needs.**

---

**What God Tells Us** - Fill in the blanks from the Word List .

1. We should \_\_\_\_\_for help in all our needs.
2. God hears\_\_\_\_\_our prayers.
3. Sometimes God does not \_\_\_\_\_our prayers right away.
4. \_\_\_\_\_wants us to keep on praying.
5. We need to ask God for \_\_\_\_\_every day
6. Sometimes God sends us trails to strengthen our \_\_\_\_\_.
7. We know that God's best answer to our prayers is \_\_\_\_\_life in faith.

**Word List**

answer  
forgiveness  
eternal  
pray  
God  
all  
faith

## Passages

**Psalms 50:15** Call upon Me in the day of trouble; I will deliver you,  
and you shall glorify Me."

**Matthew 11:28** Come to Me, all you who labor and are heavy laden, and I will give you rest.

**Lamentations 3:22-23** Through the Lord's mercies we are not consumed,  
Because His compassions fail not. They are new every morning;  
Great is Your faithfulness.

## Hymn and Prayer

Read Hymn 457.

**Your Turn** - Use ideas from the story, the Bible passages and hymn verses to write a prayer asking the Lord for help.

## Prayer

Dear God, you have shown us in this story that even through You may severely test our faith in You, surely You desire us to keep our faith. Help us always to strongly and faithfully trust and hope in You to the end, that by faith in Your saving work, we may enter Your everlasting home and be with You forever. Amen.

# The Transfiguration

Matthew 17:1-9; Mark 9:2-10; Luke 9:28-36

Why do you think the people are bowing down in the picture?

When might people kneel at church?

## Prayer

Dear Father in heaven,

We thank You that You sent Jesus to be our heavenly Savior. We know that You are pleased in Him because He saved us from our sins. Help us to remember that Jesus is Your Son. Help us also to be Your children and to do the things that please You. Amen

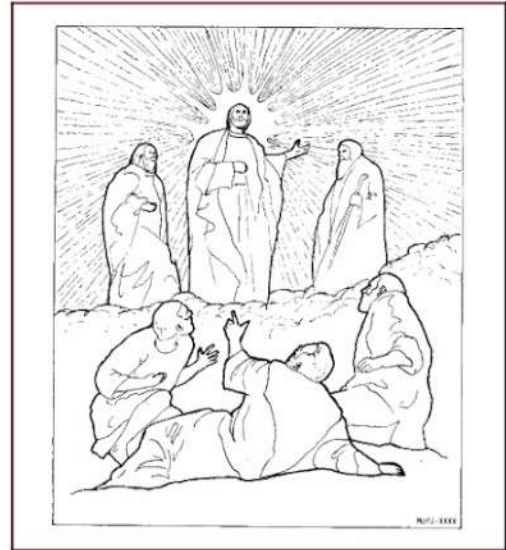

## The Story - Matthew 17:1-9

Now after six days Jesus took Peter, James, and John his brother, led them up on a high mountain by themselves;<sup>2</sup>and He was transfigured before them. His face shone like the sun, and His clothes became as white as the light.

<sup>3</sup>And behold, Moses and Elijah appeared to them, talking with Him.

<sup>4</sup>Then Peter answered and said to Jesus, "Lord, it is good for us to be

here; if You wish, let us make here three tabernacles: one for You, one for Moses, and one for Elijah."

<sup>5</sup>While he was still speaking, behold, a bright cloud overshadowed them; and suddenly a voice came out of the cloud, saying, "This is My beloved Son, in whom I am well pleased. Hear Him!"

<sup>6</sup>And when the disciples heard it, they fell on their faces and were



greatly afraid. <sup>7</sup>But Jesus came and touched them and said, "Arise, and do not be afraid."

<sup>8</sup>When they had lifted up their eyes, they saw no one but Jesus only.

<sup>9</sup>Now as they came down from the mountain, Jesus commanded them, saying, "Tell the vision to no one until the Son of Man is risen from the dead."

---

## Outer Aim

**Jesus shows the disciples He is the true God.**

---

### Recalling Details

1. How many disciples went with Jesus to the mountain?
2. What did Jesus start to do when they got to the mountain?
3. Who were the two men with Jesus?
4. What did Peter want to do?
5. Who spoke from the cloud?
6. What did Jesus ask the disciples not to do?

## Discussion Questions

1. How was Jesus different from other men?
2. How was Jesus the same as other men?
3. Was Jesus trying to show He was God or man?
4. What things did Jesus know would soon be happening to Him?
5. Why do you think Jesus told the disciples they shouldn't tell others about the transfiguration?

---

## Inner Aim

**Jesus shows us He is our God and our Savior.**

---

## Passages

John 1:14 - And the Word became flesh and dwelt among us, and we beheld  
His glory, the glory as of the only  
begotten of the Father, full of grace and truth.

John 10:17-18 - Therefore My Father loves Me, because  
I lay down My life that I may take it again.  
No one takes it from Me, but I lay it down of Myself.  
I have power to lay it down, and  
I have power to take it again.

## Hymn - TLH 135 v. 1, 2, 3, 5

'Tis good, Lord, to be here,  
Thy glory fills the night;  
Thy face and garments, like the sun,  
Shine with unborrowed light.

Fulfiller of the past,  
Promise of things to be,  
We hail Thy body glorified  
And our redemption see.

'Tis good, Lord, to be here,  
Thy beauty to behold  
Where Moses and Elijah stand,  
Thy messengers of old.

'Tis good, Lord, to be here.  
Yet we may not remain;  
But since Thou bidst us leave the mount,  
Come with us to the plain.

Underline names from the lesson.

What are we asking Jesus to do for us in the last stanza where it says, "Come with us to the plain"?

**Your Turn** - Use ideas from the story, passages and hymn to help you complete the following questions.

How do we show Jesus we love Him?

Why did Jesus lay down His life?

## Prayer

Dear Lord Jesus,

We don't know what You look like in all Your glory. We sinners have failed to be holy. But we also know Your great love for us. You became a human being and gave Your holy life as payment for our sins. We see how You prepared and strengthened Your disciples to face the difficult months ahead. Strengthen our faith. Keep the image of Your Love and the heavenly goal You have won for us before our eyes. We will see Your glory and worship You for all eternity. We pray trusting in Your name. Amen.

# The Parable of the Unforgiving Servant

Matthew 18:21-35

What if your friend lied to you and you found out about it?  
What if your friend told someone else your secret?  
What if that friend made fun of you or hurt you in some way?  
How would you feel toward him or her?  
Would it be easy to forgive him or her?  
What if your friend kept sinning against you? Should you still keep forgiving him or her?

In our parable today, Peter asked Jesus a similar question. Jesus told Peter the parable of the unforgiving servant. In this parable Jesus demonstrates how the Lord reveals a most forgiving heart in contrast to the hardness of human nature.



## Prayer

Dear Father in Heaven, Bless our study of Your Word today and help us to apply the lessons we will learn through our study. Thank You for loving us so much that You sent Your only Son, Jesus, to pay for our sins, even though we do not deserve Your mercy and forgiveness. Let Your love and forgiveness motivate us to forgive and love others. In Jesus' name. Amen.

## The Story - Matthew 18:21-38

Matthew 18:21 Then Peter came to Him and said, "Lord, how often shall my brother sin against me, and I forgive him? Up to seven times?"

{22} Jesus said to him, "I do not say to you, up to seven times, but up to seventy times seven.

{23} "Therefore the kingdom of heaven is like a certain king who wanted to settle accounts with his servants. {24} "And when he had begun to settle accounts, one was brought to him who owed him ten thousand talents. {25} "But as he was not able to pay, his master commanded that he be sold, with his wife and children and all that he had, and that payment be made.

{26} "The servant therefore fell down before him, saying, 'Master, have patience with me, and I will pay you all.' {27} "Then the master of that servant was moved with compassion, released him, and forgave him the debt.

{28} "But that servant went out and found one of his fellow servants who owed him a hundred denarii; and he laid hands on him and took him by the throat, saying, 'Pay me what you owe!'

{29} "So his fellow servant fell down at his feet and begged him, saying, 'Have patience with me, and I will pay you all.'

{30} "And he would not, but went and threw him into prison till he should pay the debt. {31} "So when his fellow servants



saw what had been done, they were very grieved, and came and told their master all that had been done.

{32} "Then his master, after he had called him, said to him, 'You wicked servant! I forgave you all that debt because you begged me. {33} 'Should you not also have had compassion on your

fellow servant, just as I had pity on you?' {34} "And his master was angry, and delivered him to the torturers until he should pay all that was due to him.

{35} "So My heavenly Father also will do to you if each of you, from his heart, does not forgive his brother his trespasses."

### **Outer Aim - Jesus told a parable about the forgiveness of sins.**

**What the Story Tells Us** - You may wish to have the class act out the parable. Go over these discussion questions.

1. How many times did Peter think he should forgive his brother?
2. What was Jesus' response to Peter?
3. What was Jesus really saying by this response?
4. In the parable, who represents the king?
5. What did the king do for the servant who owed him a debt?
6. What has God done for each of us?
7. Did we earn this forgiveness?
8. When this servant found a fellow servant who owed him a debt, the servant was not merciful or forgiving. Did this show that he was appreciative of the king's mercy in canceling his debt?
9. When the king found out about how the servant treated his fellow servant, what did the king do?
10. The king asked the wicked servant, "Shouldn't you have had mercy on your fellow servant just as I had on you?" What is the correct answer?
11. Why should we be willing and eager to forgive?
12. Who should we be willing and eager to forgive?



**What God's Word Tells Us** - Fill in the blanks with the appropriate word that completes the sentence. One letter in each word has been given to you. Take these given letters and write them below to begin the passage that Jesus spoke on the cross.

1. The master F \_\_\_\_\_ the servant his debt.
2. The servant owed his master 10,000 \_\_ A \_\_\_\_\_ .
3. \_\_\_ T \_\_\_ asked Jesus the question about forgiveness.
4. God wants us to forgive our brother from the H \_\_\_\_\_ .
5. Peter thought we should forgive our neighbor \_\_ E \_\_\_\_\_ times.
6. The second servant owed a debt of a hundred \_\_\_\_\_ R \_\_\_\_\_ .
7. The wicked servant was \_\_\_ F \_\_\_\_\_ .
8. The king in the parable represents \_\_ O \_\_\_\_\_ .
9. The king sent the wicked servant into \_\_ R \_\_\_\_\_ .
10. When we are unforgiving it \_\_\_ G \_\_\_\_\_ God.
11. God has forgiven our \_\_ I \_\_\_\_\_ .
12. Forgiveness should be a daily part of our \_\_\_ V \_\_\_\_\_ .
13. We should forgive even our \_\_\_ E \_\_\_\_\_ .

UNFORGIVING  
 ENEMIES  
 GOD  
 SINS  
 FORGAVE  
 HEART  
 LIVES  
 PRISON  
 TALENTS  
 PETER  
 ANGERS  
 DENARII  
 SEVEN

" \_\_\_\_\_ , \_\_\_\_\_ them; for they do not know that they do."  
 Luke 23:34

## Passages

Matthew 5:44 - But I say to you, love your enemies, bless those who curse you, do good to those who hate you, and pray for those who spitefully use you and persecute you.

The Fifth Petition © Sydow Catechism 2000

"And forgive us our trespasses as we forgive those who trespass against us."

What does this mean?

We pray in this petition that our Father in heaven would not look on our sins or deny our prayer because of them. We are not worthy of things for which we are asking, neither have we deserved them. However, we ask that our Father would by His grace give us what we ask; even though we sin often every day and indeed deserve nothing but punishment. We, too, will from our hearts gladly forgive and do good to all those who sin against us.

**Inner Aim** - We are to forgive others as God in Christ has forgiven us.

**Your Turn** - WORD SEARCH - Find the words from the Word Box in the puzzle below. The words can go across, down, diagonal and backwards.

FORGIVE  
 DENARII  
 PETER  
 ENEMIES  
 PRISON  
 TALENTS  
 SINS  
 SERVANT  
 KING  
 DEBT

F	R	O	G	I	V	S	K	I	N	D
O	O	R	F	I	I	T	A	L	E	S
G	O	R	E	S	S	U	V	B	B	E
F	A	N	G	R	E	S	T	R	P	R
T	D	E	B	I	R	T	M	O	R	E
S	N	I	S	G	V	N	N	P	I	M
R	T	B	N	R	A	E	R	R	S	E
T	E	I	P	S	N	L	S	I	O	M
E	K	I	S	O	T	A	T	S	N	A
P	E	S	A	P	E	T	E	R	V	T
G	D	E	N	A	R	I	I	T	A	I
S	E	R	V	P	S	M	R	A	N	S
M	N	S	E	I	M	E	N	E	T	E

**Hymn** - TLH #458 v. 1, 6

Our Father, Thou in heav'n above,  
 Who biddest us to dwell in love,  
 As brethren of one family,  
 To cry in ev'ry need to Thee,  
 Teach us no thoughtless words to say,  
 But from our inmost heart to pray.

Forgive our sins, Lord, we implore,  
 Remove from us their burden sore,  
 As we their trespasses forgive  
 Who by offenses us do grieve.  
 Thus let us dwell in charity  
 And serve our brother willingly.

**Prayer** - The Lord's Prayer

## Pharisee & Publican

Luke 18:9-15

How would you feel if a homeless person or a drug addict came into your church on a Sunday morning and sat next to you? Would you feel like moving to different place, or would you be glad that he/she had come to your church? Sometimes Christians feel that they are better than other people.

Today we will hear a parable in which Jesus showed the Pharisees that they could not be saved by the outwardly good lives they lived. True righteousness comes only through faith in Jesus and His death which paid for our sins.



### Prayer

Just as I am without one plea  
But that Thy blood was shed for me  
And that Thou bidd'st me come to Thee,  
O Lamb of God, I come, I come.

Just as I am and waiting not  
To rid my soul of one dark blot,  
To Thee, whose blood can cleanse each spot,  
O Lamb of God, I come, I come. Amen

### The Pharisee and the Publican Luke 18: 9 -14

Luke 18:9 Also He spoke this parable to some who trusted in themselves that they were righteous, and despised others: {10} "Two men went up to the temple to pray, one a Pharisee and the other a tax collector. {11} "The Pharisee stood and prayed thus with himself, 'God, I thank You that I am not like other men; extortioners, unjust, adulterers, or even as this tax collector. {12} 'I fast twice a week; I give tithes of all that I possess.'

{13} "And the tax collector, standing afar off, would not so much as raise his eyes to heaven, but beat his breast, saying, 'God, be merciful to me a sinner!'

{14} "I tell you, this man went down to his house justified rather than the other; for everyone who exalts himself will be humbled, and he who humbles himself will be exalted."

**Outer Aim - The Pharisee trusted in himself. The Publican looked to Jesus for salvation.**



**What the Story Tells Us** - Complete the sentences. Place an X in front of the best ending for each sentence.

1. The Pharisee was ...

- a. \_\_\_\_ better than other people.
- b. \_\_\_\_ merciful to the tax collector.
- c. \_\_\_\_ a sinner.

2. The Pharisee told God ...

- a. \_\_\_\_ about the good things he did.
- b. \_\_\_\_ about his sin.
- c. \_\_\_\_ about how good the tax collector was.

3. The tax collector asked God to ...

- a. \_\_\_\_ notice how good he was.
- b. \_\_\_\_ take away his sins.
- c. \_\_\_\_ punish him for his sins.

4. The man who was forgiven was ...

- a. \_\_\_\_ the Pharisee.
- b. \_\_\_\_ the tax collector.

5. The Pharisee was as sinful as the tax collector because ...

- a. \_\_\_\_ all people are sinful in their hearts.
- b. \_\_\_\_ he did not go to the temple.
- c. \_\_\_\_ he prayed too loudly.

6. God wants us to ...

- a. \_\_\_\_ confess our sins.
- b. \_\_\_\_ make believe that we have no sins.
- c. \_\_\_\_ tell Him that we are better than most people.

7. When we have done something wrong, God wants us to ...

- a. \_\_\_\_ run away.
- b. \_\_\_\_ say that someone else did it.
- c. \_\_\_\_ ask for forgiveness.

8. Our sins are taken away ...

- a. \_\_\_\_ by what we do.
- b. \_\_\_\_ by what Jesus did for us.
- c. \_\_\_\_ by waiting until people forgive us.

**What God's Word Tells Us** - Find the letter that goes with the number below each blank, and you will have the words that we should pray. Use the code in the box.

<b>A</b>	<b>B</b>	<b>C</b>	<b>D</b>	<b>E</b>	<b>F</b>	<b>G</b>	<b>I</b>	<b>L</b>	<b>M</b>	<b>N</b>	<b>O</b>	<b>R</b>	<b>S</b>	<b>T</b>	<b>U</b>
<b>1</b>	<b>2</b>	<b>3</b>	<b>4</b>	<b>5</b>	<b>6</b>	<b>7</b>	<b>8</b>	<b>9</b>	<b>10</b>	<b>11</b>	<b>12</b>	<b>13</b>	<b>14</b>	<b>15</b>	<b>16</b>

\_\_\_    \_\_\_    \_\_\_                    \_\_\_    \_\_\_                    \_\_\_    \_\_\_    \_\_\_    \_\_\_    \_\_\_    \_\_\_    \_\_\_

7    12    4                    2    5                    10    5    13    3    8    6    16    9

\_\_\_    \_\_\_                    \_\_\_    \_\_\_                    \_\_\_                    \_\_\_    \_\_\_    \_\_\_    \_\_\_    \_\_\_    .

15    12                    10    5                    1                    14    8    11    11    5    13

**Inner Aim** - Believers rely only on Jesus for salvation.

**Your Turn**

1. Why do you think the Pharisee did even more than God had commanded?
2. What did the Pharisee think of himself in comparison with others such as the tax collector?
3. How did the tax collector show that he knew he was a sinner? Name three things that he did.
4. On what did the tax collector base his hope of forgiveness?

\_\_\_ his good works    \_\_\_ the mercy of God    \_\_\_ his humility

## Passages

1 John 1:8 - If we say that we have no sin, we deceive ourselves,  
and the truth is not in us.

Psalm 51:17 - The sacrifices of God are a broken spirit, a broken and  
a contrite heart - these, O God , You will not despise.

Romans 3:23 -24 - For all have sinned and fall short of the glory of God,  
being justified freely by His grace through the redemption that is in Christ Jesus.

## Hymn - TLH #370

My hope is built on nothing less  
Than Jesus' blood and righteousness;  
I dare not trust the sweetest frame,  
But wholly lean on Jesus' name.  
On Christ the solid Rock, I stand;  
All other ground is sinking sand.

When He shall come with trumpet sound,  
Oh, may I then in Him be found,  
Clothed in His righteousness alone,  
Faultless to stand before the throne.  
On Christ the solid Rock I stand;  
All other ground is sinking sand.

## Prayer

Lord Jesus,

Teach us to be humble and aware of our sinfulness and need of a Savior just like  
the tax collector. Keep us from trusting in ourselves and help us to look to You for  
forgiveness and salvation. Every day we need to come to You and say, "Lord be  
merciful to me, a sinner." Amen

## Jesus and the Children

Matthew 18:1-6; Mark 10:13-16; Luke 9:46-48

Who is more important, adults or children?  
This question has many answers.

Can anyone remain a child for ever?

### Prayer

Dear Father in heaven, we praise You for sending Your Son to die for us. We are thankful that You love all people including children. Help us to learn from this lesson the ways to remain Your true children.

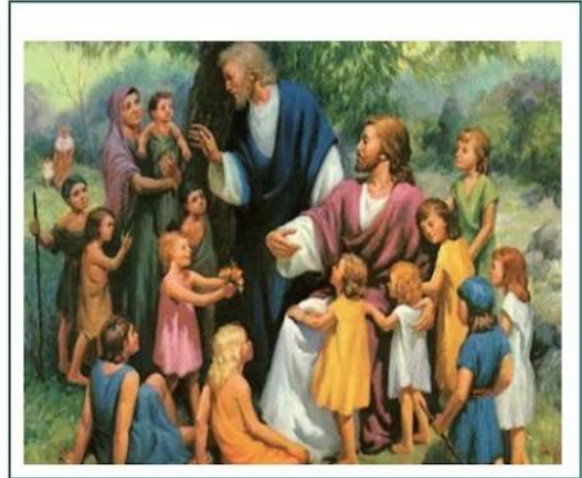

### The Story

#### Jesus and the Children:

**Jesus Teaches with Children - Luke 9:46-48; Matthew 18:1-6,10; Mark 10:13-16**

**Jesus Blesses Them - Luke 18:15-17; Matthew 19:13-15; Mark 10:13-16**

The disciples argued about who was best. Jesus knew what they were thinking and asked them about it.

The disciples asked Him, "Who is the greatest in the kingdom of heaven?"

Then Jesus took a little child in His arms. He said, "Unless you are converted and become as little children, you will never go to heaven. Whoever is humble like a little child is the greatest in the kingdom of heaven. Whoever treats

a little child like a Christian should, treats Me the same way and whoever treats Me kindly treats the Father the same way. Whoever is least among you will be great. But whoever tricks one of these little ones to sin is in big trouble. It would be better for him if a huge stone were hung around his neck, and he were drowned in the deep sea.

Another time, they also brought babies to Jesus so He could hold them and pray for them. The disciples saw the people bring the



children and told them to go away.  
Jesus didn't like what He saw.  
He said, "Let the little children come to Me, and do not make them go away. The kingdom of heaven is

made for them, too. Whoever does not have child-like faith, will not be in heaven." And He laid His hands on them and blessed them.

### What the Story Tells Us

1. What were the disciples fighting about?
2. How does Jesus feel about boasting?
3. Who did the disciples tell to go away?
4. How could the disciples show Jesus they understood how to act in heaven?

---

### Outer Aim

**Jesus taught His disciples to be child-like in faith.**

---

**What God Tells Us** - Mark your answers as (T)true or (F)alse.

1. \_\_\_\_\_ Jesus knew what the disciples were thinking.
2. \_\_\_\_\_ The disciples were acting like Christians.
3. \_\_\_\_\_ Punishment is worse for people who trick children about God.
4. \_\_\_\_\_ God loves adults more than children.
5. \_\_\_\_\_ Children are sinless.

### Passages

**James 4:6-7 - But He gives more grace. Therefore He says: "God resists the proud, but give grace to the humble." Therefore submit to God. Resist the devil and he will flee from you.**

**Proverbs 3:5-6 - Trust in the LORD with all your heart, and lean not on your own understanding; in all your ways acknowledge Him, and He shall direct your paths.**



---

## Inner Aim

**A child-like faith looks to Jesus for all things.**

---

## Hymn

Read Hymn 627. In stanza one, to what are children being compared?

**Your Turn** - Use ideas from the story, passages, and hymn to help you complete the following activities.

What would you tell a parent who was concerned about their baby fussing in church?

How and why should a Christian become childlike?

## Prayer

Dear Lord Jesus, in the lesson today You are telling me how precious I am to You. You assure me that Your angels are watching over me, and that I too can receive the great blessings of forgiveness and salvation that You have purchased for me. I ask Your blessing upon me today also. I ask you to bless me and help me to be humble and trusting. Remind me that I need You every day of my life. Thank You for caring for each of us, even though we are very young, and bring us all one day to live with You in heaven. Amen.

# The Good Samaritan

Luke 10:25-37

How many people are helping someone in this picture?

How else can one help others?

Why do we behave this way?

## Prayer

Lord, open Thou our hearts to hear,  
And through Thy Word to us draw near;  
Let us Thy Word e'er pure retain,  
Let us Thy children and heirs remain.



## The Parable of the Good Samaritan - Luke 10:25-37

And behold, a certain lawyer stood up and tested Him, saying, "Teacher, what shall I do to inherit eternal life?"

{26} He said to him, "What is written in the law? What is your reading of it?"

{27} So he answered and said, " 'You shall love the LORD your God with all your heart, with all your soul, with all your strength, and with all your mind,' and 'your neighbor as yourself.' "

{28} And He said to him, "You have answered rightly; do this and you will live."

{29} But he, wanting to justify himself, said to Jesus, "And who is my neighbor?"

{30} Then Jesus answered and said: "A certain man went down from Jerusalem to Jericho, and fell among thieves, who stripped him of his clothing, wounded him,

and departed, leaving him half dead. {31} "Now by chance a certain priest came down that road. And when he saw him, he passed by on the other side.

{32} "Likewise a Levite, when he arrived at the place, came and looked, and passed by on the other side.

{33} "But a certain Samaritan, as he journeyed, came where he was. And when he saw him, he had compassion. {34} "So he went to him and bandaged his wounds, pouring on oil and wine; and he set him on his own animal, brought him to an inn, and took care of him.

{35} "On the next day, when he departed, he took out two denarii, gave them to the innkeeper, and said to him, 'Take care of him; and whatever more you spend, when I come again, I will repay



you.'

{36} "So which of these three do you think was neighbor to him who fell among the thieves?"

{37} And he said, "He who showed mercy on him." Then Jesus said to him, "Go and do likewise."

**What the Story Tells Us** - Show whether the following sentences are true or false by circling the letters in the **True** or **False** column. The letters you circle complete the sentence at the bottom of the section.

	<u>True</u>	<u>False</u>
1. A lawyer came to Jesus to learn from Him.	K	W
2. He needed to learn who his neighbor was.	O	M
3. Jesus told him a parable to help him understand.	R	S
4. The good Samaritan was attacked by thieves.	F	D
5. The thieves stole from and wounded the man.	S	T
6. The priest stopped to help the wounded man.	P	A
7. The Levite showed love for the man.	L	C
8. The Samaritan took the man to his home.	J	T
9. He paid someone to care for the wounded man.	I	H
10. A Samaritan showed love for his neighbor by helping him.	O	F
11. Jesus used the parable to show how to inherit eternal life.	E	N
12. Jesus told the man to love as the Samaritan did.	S	U

We show love for our neighbor with

\_\_\_\_\_ and \_\_\_\_\_.

---

**Outer Aim**

**Jesus showed how a man was a neighbor to a stranger.**

---

## What God Tells Us - Love = Action!

How did Jesus show His love for you? You can thank and praise Him by being a neighbor to others. List one way you can show love to each of the neighbors listed below.

Mom or Dad \_\_\_\_\_

Grandparents \_\_\_\_\_

Brother or Sister \_\_\_\_\_

Classmate \_\_\_\_\_

Non-Christian friend \_\_\_\_\_

Neighbor \_\_\_\_\_

A poor family \_\_\_\_\_

An orphan in India \_\_\_\_\_

---

### Inner Aim

**God's love prompts us to love all men as neighbors.**

---

**Passages** - Fill in the blanks in the passages below.

**Luke 10:27** - So he \_\_\_\_\_ and said, " 'You shall \_\_\_\_\_ the \_\_\_\_\_ your \_\_\_\_\_ with all your \_\_\_\_\_, with all your \_\_\_\_\_, with all your \_\_\_\_\_, and with all your \_\_\_\_\_,' and your \_\_\_\_\_ as \_\_\_\_\_.' "

**Ephesians 2:8** - For by \_\_\_\_\_ you have been \_\_\_\_\_ through \_\_\_\_\_, and that not of \_\_\_\_\_; *it is* the \_\_\_\_\_ of \_\_\_\_\_, not of \_\_\_\_\_, lest anyone should \_\_\_\_\_. For we are His \_\_\_\_\_, created in Christ Jesus for \_\_\_\_\_, which God \_\_\_\_\_ beforehand that we should \_\_\_\_\_ in them.

**Galatians 3:28** - There is neither \_\_\_\_\_ nor \_\_\_\_\_, there is neither \_\_\_\_\_ nor \_\_\_\_\_, there is neither \_\_\_\_\_ nor \_\_\_\_\_; for you are all \_\_\_\_\_ in \_\_\_\_\_.

## Hymn

Read Hymn 405. Which verses are most appropriate for today's lesson? Why do you think so?

## Your Turn

You spend your Saturdays volunteering at the local nursing home. Your friend questions why you are "wasting" your Saturday afternoons. Use ideas from the story and Bible passages to answer your friend.

There is a student at school who has been teasing and bullying you all year. That student is now struggling with a math assignment that you understood. How could you follow the example of the Samaritan. Why would you do so?

## Prayer

Dear Jesus,

You have shown us perfect love by dying on the cross for us. Because You took away our sins, we will live eternally with You! Forgive us when we do not love our neighbor as You have loved us. Help us to show love with our words and actions to those in need. Help us to see to our neighbor and their needs. In Your name we pray. Amen.

## Mary & Martha

Luke 10:38-42

If Jesus came to visit you, what would you do? Would you clean the house, cook a fancy meal, or just sit and talk with Him?

In our story today you will meet two sisters who invited Jesus to their home. They both loved Him and wanted to serve Him. Let's find out which one chose the best way to serve her Lord.

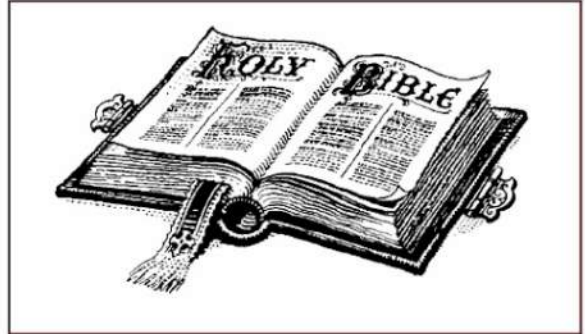

### Prayer

Dear Lord Jesus, as we study Your Word today, help us to be like Mary, eager to hear every word and happy to have this opportunity to learn more about You. We pray that You would open our hearts as Your Word is taught so that our faith will grow and be strengthened. Bless our study today. In Your name we pray. Amen

### The Story

Now it happened as they went that He entered a certain village; and a certain woman named Martha welcomed Him into her house.

{39} And she had a sister called Mary, who also sat at Jesus' feet and heard His word. {40} But Martha was distracted with much serving, and she approached Him and said, "Lord, do You not care that my sister has left me to serve alone? Therefore tell her to help me."

{41} And Jesus answered and said to her, "Martha, Martha, you are

worried and troubled about many things. {42} "But one thing is needed, and Mary has chosen that good part, which will not be taken away from her."

---

**Outer Aim - Hearing God's Word was the most important thing for Mary.**

---



**What the Story Tells Us** - Discuss the following questions.

1. Was it wrong for Martha to spend time preparing a meal for her Lord? Why or why not?
2. Was it wrong for Martha to become angry at Mary for not helping her? Why or why not?
3. When do we sit at Jesus' feet and have a chance to hear and learn His Word?
4. What are some of the things that might keep us from gladly hearing Jesus' word?
5. Why is the study of God's Word more important than anything else?

**What God's Word Tells Us** - Cross out the wrong word in each sentence, and write the correct word on the line.

1. Jesus went to visit Mary and Martha who lived in Bethlehem.  
\_\_\_\_\_
2. When Jesus started teaching the Word of God, Mary sat and slept.  
\_\_\_\_\_
3. Martha did not listen to Jesus' words because she was busy eating a meal.  
\_\_\_\_\_
4. Martha thought that Mary should be listening. \_\_\_\_\_
5. Jesus said, "Martha, there is only one thing that is very important, and that is my dinner." \_\_\_\_\_

6. Jesus said, "Mary has chosen the bad part which shall never be taken away from her." \_\_\_\_\_
7. It is hard for us to watch TV instead of reading and studying God's Word.  
\_\_\_\_\_
8. God wants us to sleep late or to go fishing on Sunday mornings rather than going to church. \_\_\_\_\_
9. God says that hearing His Word is less important than other things.  
\_\_\_\_\_
10. Through the Word of God the Holy Spirit works doubt in our hearts. \_\_\_\_\_

**Your Turn** - Use your Bibles to look up the following Bible verses and match them to the phrase that fits them best. Put the correct letter in the blank.

**A.** 1 Peter 2:2    **B.** 2 Timothy 3:15 - 16    **C.** Romans 10:17    **D.** Luke 11:28

- \_\_\_\_\_ You will be happy if you hear the Word of God and also hold on to it.
- \_\_\_\_\_ The Word of God creates faith in the hearts of hearers.
- \_\_\_\_\_ The Bible is the word of God, not just the words of men.
- \_\_\_\_\_ We should be hungry for the Word of God.

---

**Inner Aim - Hearing God's Word is the most important thing for His people.**

---



## Passages

Luke 11:28 - Blessed are those who hear the word of God and keep it!

2 Timothy 3:15 - From childhood you have known the Holy Scriptures, which are able to make you wise for salvation through faith which is in Christ Jesus.

Romans 10:17 - So then faith comes by hearing, and hearing by the word of God.

## Hymn - TLH #285

Discuss the words: *Book Divine, inspiration, doctrines, trod, grace, tedious night of life, eternal day*

How precious is the Book Divine,  
By inspiration given!  
Bright as a lamp its doctrines shine  
To guide our souls to heav'n.

It shows to man his wand'ring ways  
And where his feet have trod,  
And brings to view the matchless grace  
Of a forgiving God.

Its light, descending from above  
Our gloomy world to cheer,  
Displays a Savior's boundless love  
And brings His glories near.

This lamp through all our tedious night  
Of life shall guide our way  
Till we behold the clearer light  
Of an eternal day.

## Prayer

Lord Jesus, make us eager to serve You as Mary and Martha did. Forgive us for the times we have neglected to hear and learn Your Word as we should. Help us realize how important Your Word is, so that we will choose it above other things as Mary did. Send Your Holy Spirit to strengthen our faith through the hearing of Your Word so that we will always put You first in our lives. Make us faithful hearers of Your Word. Amen.

# The Prodigal Son

Luke 15:11-32

Why did Jesus tell stories?

What would Jesus say to people who accuse Him of visiting sinful people and eating with them?

Look at this picture. Do you remember what it shows? Let's read more about the lesson.



## Prayer

Dear Father,

In this parable, You show me how much I am loved by You. I do not deserve Your love, yet You give it freely because of Your son's death on the cross. Help me to remember at all times that no matter what I have done wrong, You have freely forgiven me all my sins. Please give me now a spirit that is not jealous of this love and forgiveness, but one that makes me eager to share it with my neighbors, friends and family. In Jesus' name I ask this. Amen.

## The Prodigal Son (The Wasteful Son) - Luke 15:11-32

Then He said: "A certain man had two sons. {12} "And the younger of them said to his father, 'Father, give me the portion of goods that falls to me.' So he divided to them his livelihood. {13} "And not many days after, the younger son gathered all together, journeyed to a far country, and there wasted his possessions with prodigal living.

{14} "But when he had spent all, there arose a severe famine in that land, and he began to be in want. {15} "Then he went and joined himself to a citizen of that country, and he sent him into his fields to feed swine. {16} "And he would gladly have filled his stomach with the pods that the swine ate, and no one gave him anything.



{17} "But when he came to himself, he said, 'How many of my father's hired servants have bread enough and to spare, and I perish with hunger! {18} 'I will arise and go to my father, and will say to him, "Father, I have sinned against heaven and before you, {19} "and I am no longer worthy to be called your son. Make me like one of your hired servants."

{20} "And he arose and came to his father. But when he was still a great way off, his father saw him and had compassion, and ran and fell on his neck and kissed him. {21} "And the son said to him, 'Father, I have sinned against heaven and in your sight, and am no longer worthy to be called your son.'

{22} "But the father said to his servants, 'Bring out the best robe and put it on him, and put a ring on his hand and sandals on his feet. {23} 'And bring the fatted calf here and kill it, and let us eat and be merry; {24} 'for this my son was dead and is alive again; he was lost and is found.' And they began to be merry.

{25} "Now his older son was in the field. And as he came and drew near to the house, he heard music and dancing. {26} "So he called one of the servants and asked what these things meant. {27} "And he said to him, 'Your brother has come, and because he has received him safe and sound, your father has killed the fatted calf.'

{28} "But he was angry and would not go in. Therefore his father came out and pleaded with him. {29} "So he answered and said to his father, 'Lo, these many years I have been serving you; I never transgressed your commandment at any time; and yet you never gave me a young goat, that I might make merry with my friends. {30} 'But as soon as this son of yours came, who has devoured your livelihood with harlots, you killed the fatted calf for him.'

{31} "And he said to him, 'Son, you are always with me, and all that I have is yours. {32} 'It was right that we should make merry and be glad, for your brother was dead and is alive again, and was lost and is found.'"

---

**Outer Aim - Jesus tells the parable of a foolish son who was lost and then found.**

---

**What the Lesson Tells Us** - Answer the following questions about the lesson.

1. What wicked things did the younger son do?
2. Why did the son get hungry during the famine?

3. How was the famine a good thing for the son?
4. What did he decide to say to his father?
5. Why did the father have a party?
6. Why was the older son upset?
7. How did he show he was angry?
8. Why did the father go out to talk to the older son?
9. Who was the father in the parable?
10. Who were the sons?
11. What did Jesus mean by the younger son going away and wasting his goods with sinful living?
12. What did Jesus mean by having the father waiting when the son was still a long way away?
13. How should we feel about someone who repents?

---

**Inner Aim - Jesus wants us to know we are forgiven and to forgive others.**

---

## **What God Tells Us**

1. How are we like the prodigal son?
2. How does God feel about us even though we have sinned?
3. How should we feel about other people and their sins?

**Your Turn** - Use the hymn verse and Bible passages to answer and discuss the following questions.

O Thou that hear'st when sinners cry  
Tho' all my crimes before Thee lie,  
Behold them not with angry look,  
But blot their mem'ry from Thy book.

What does God do with the sins that are written down in His book? (Hymn 325 v. 1)

"I say to you that likewise there will be more joy in heaven over one sinner  
who repents than over ninety-nine just persons  
who need no repentance." Luke 15:7

Which makes God happy? (Luke 15:7)

"Who desires all men to be saved and to come to  
the knowledge of the truth." 1 Timothy 2:4

What does God want for sinners? (1 Timothy 2:4)

"If we confess our sins, He is faithful and just to forgive us our sins  
and to cleanse us from all unrighteousness." 1 John 1:9

What does God do with the sins we confess? (1 John 1:9)

## Prayer

Psalm 103:2-5 - "Bless the LORD, O my soul, and forget not all His benefits: Who forgives all your iniquities, Who heals all your diseases, Who redeems your life from destruction, Who crowns you with loving kindness and tender mercies, Who satisfies your mouth with good things, so that your youth is renewed like the eagle's. " Amen.

## Parable of the Rich Man and Poor Lazarus

Luke 16:19-31

1. Where do you hear and learn the Word of God?
2. What does hearing and learning God's Word do for you?
3. Who teaches you God's Word?

### Prayer

Dear Father in heaven,

We thank You for Your precious Word. Please bless our study of Your Word. Help us to share Your Word with others, so that they too may learn of its saving power. In Jesus' name. Amen.

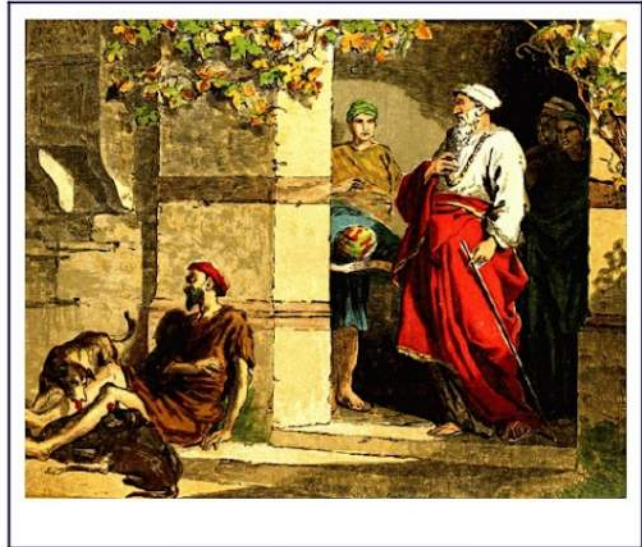

*The Rich Man and Lazarus*

### Parable of the Rich Man and Poor Lazarus (Luke 16:19-31)

Jesus spoke to the Pharisees who were lovers of money. He said, 19 "There was a certain rich man who was clothed in purple and fine linen and fared sumptuously every day. 20 But there was a certain beggar named Lazarus, full of sores, who was laid at his gate, 21 desiring to be fed with the crumbs which fell from the rich man's table. Moreover

the dogs came and licked his sores.

22 "So it was that the beggar died, and was carried by the angels to Abraham's bosom. The rich man also died and was buried. 23 "And being in torments in Hades, he lifted up his eyes and saw Abraham afar off, and Lazarus in his bosom.

24 "Then he cried and said, 'Father Abraham, have mercy on



me, and send Lazarus that he may dip the tip of his finger in water and cool my tongue; for I am tormented in this flame.'

25 "But Abraham said, 'Son, remember that in your lifetime you received your good things, and likewise Lazarus evil things; but now he is comforted and you are tormented. 26 'And besides all this, between us and you there is a great gulf fixed, so that those who want to pass from here to you cannot, nor can those from there pass to us.'

27 "Then he said, 'I beg you therefore, father, that you would send him to my father's house, 28 'for I have five brothers, that he may testify to them, lest they also come to this place of torment.'

29 "Abraham said to him, 'They have Moses and the prophets; let them hear them.'

30 "And he said, 'No, father Abraham; but if one goes to them from the dead, they will repent.'

31 "But he said to him, 'If they do not hear Moses and the prophets, neither will they be persuaded though one rise from the dead.'"

**Outer Aim** - Jesus tells us a parable about true riches, hearing and believing God's Word.

**What the Story Tells Us** - Fill in the blanks.

1. Jesus told this parable to \_\_\_\_\_.
2. This parable is about a \_\_\_\_\_ man and a poor man named \_\_\_\_\_.
3. The poor man had to \_\_\_\_\_ for food.
4. The poor man hoped to be fed \_\_\_\_\_ that fell from the rich man's table.

5. Lazarus was carried by angels to \_\_\_\_\_.
6. The rich man was buried and went to \_\_\_\_\_.
7. The rich man saw Lazarus in heaven with \_\_\_\_\_.
8. The rich man wanted a drop of \_\_\_\_\_ on his tongue to cool it.
9. The rich man asked Father Abraham to send Lazarus back to earth to warn his \_\_\_\_\_.
10. Abraham told the rich man that only those who believe the \_\_\_\_\_ \_\_\_\_\_ will go to heaven.

**Inner Aim** - Jesus teaches us about the power of His Word, which alone can convert and save sinners.

### **Write Yes or No**

1. \_\_\_\_\_ The Pharisees were lovers of money.
2. \_\_\_\_\_ Hard times and physical afflictions show God's disapproval of us.
3. \_\_\_\_\_ Lazarus was saved by faith.
4. \_\_\_\_\_ The rich man was condemned because of disbelief.
5. \_\_\_\_\_ Hell is a mythical place.
6. \_\_\_\_\_ The Word of God can bring a person to faith.



**Passages** - Use your Bible to complete the following.

Luke 4:4 "But \_\_\_\_\_ answered him, saying, 'It is \_\_\_\_\_  
\_\_\_\_\_ shall not live by \_\_\_\_\_ alone, but by every \_\_\_\_\_ of  
\_\_\_\_\_.'"

2 Timothy 3:15 "From \_\_\_\_\_ you have know the Holy \_\_\_\_\_  
which are \_\_\_\_\_ to make you \_\_\_\_\_ for \_\_\_\_\_ through  
\_\_\_\_\_ which is in \_\_\_\_\_."

Isaiah 55:11 "So shall my \_\_\_\_\_ be that goes \_\_\_\_\_ from my  
\_\_\_\_\_ ; it shall not \_\_\_\_\_ to Me \_\_\_\_\_, but it  
shall \_\_\_\_\_ what I \_\_\_\_\_, and it shall \_\_\_\_\_  
in the thing which I \_\_\_\_\_ it."

**Hymn/Prayer** -Use TLH 5 as your closing prayer.

Lord, open Thou my heart to hear  
And through Thy Word to me draw near;  
Let me Thy Word e'er pure retain,  
Let me Thy child and heir remain.

Thy Word doth deeply move the heart,  
Thy Word doth perfect health impart,  
Thy Word my soul with joy doth bless,  
Thy Word brings peace and happiness.

To God the Father, God the Son,  
And God the Spirit, Three in One,  
Shall glory, praise, and honor be  
Now and throughout eternity. Amen.

# Lazarus Raised from the Dead

John 11:1-46

When is this flag given out?  
What is death?  
Why do people die?  
How can we overcome death?

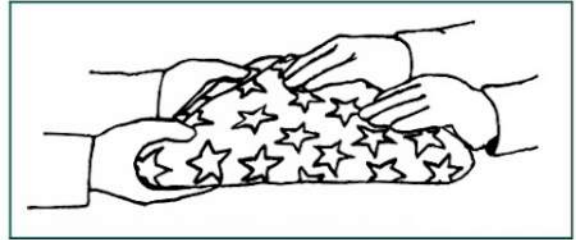

## Prayer

Dear Father in Heaven, You have sent Your Son into this world so that our sins would be forgiven. Even though we may die physically and be separated from our bodies, we pray that You give us faith to overcome spiritual death. Keep us in Your Word, so that when we die, we may live eternally with You in heaven. Amen.

## The Story - John 11:1-7, 11-46

Now a certain man was sick, Lazarus of Bethany, the town of Mary and her sister Martha. {2} It was that Mary who anointed the Lord with fragrant oil and wiped His feet with her hair, whose brother Lazarus was sick. {3} Therefore the sisters sent to Him, saying, "Lord, behold, he whom You love is sick."

{4} When Jesus heard that, He said, "This sickness is not unto death, but for the glory of God, that the Son of God may be glorified through it."

{5} Now Jesus loved Martha and her sister and Lazarus. {6} So, when He heard that he was sick, He stayed two more days in the place where He was. {7} Then after this He said to the disciples, "Let us go to Judea again."

{11} ... After that He said to them, "Our friend Lazarus sleeps, but I go that I may wake him up."

{12} Then His disciples said, "Lord, if he sleeps he will get well." {13} However,

Jesus spoke of his death, but they thought that He was speaking about taking rest in sleep.

{14} Then Jesus said to them plainly, "Lazarus is dead. {15} "And I am glad for your sakes that I was not there, that you may believe. Nevertheless let us go to him."

{16} Then Thomas, who is called the Twin, said to his fellow disciples, "Let us also go, that we may die with Him."

{17} So when Jesus came, He found that he had already been in the tomb four days. {18} Now Bethany was near Jerusalem, about two miles away. {19} And many of the Jews had joined the women around Martha and Mary, to comfort them concerning their brother.

{20} Then Martha, as soon as she heard that Jesus was coming, went and met Him, but Mary was sitting in the house. {21} Then Martha said to Jesus, "Lord, if You had been here, my brother would not have died. {22} "But even now I know that



whatever You ask of God, God will give You."

{23} Jesus said to her, "Your brother will rise again."

{24} Martha said to Him, "I know that he will rise again in the resurrection at the last day."

{25} Jesus said to her, "I am the resurrection and the life. He who believes in Me, though he may die, he shall live. {26} "And whoever lives and believes in Me shall never die. Do you believe this?"

{27} She said to Him, "Yes, Lord, I believe that You are the Christ, the Son of God, who is to come into the world."

{28} And when she had said these things, she went her way and secretly called Mary her sister, saying, "The Teacher has come and is calling for you." {29} As soon as she heard that, she arose quickly and came to Him. {30} Now Jesus had not yet come into the town, but was in the place where Martha met Him. {31} Then the Jews who were with her in the house, and comforting her, when they saw that Mary rose up quickly and went out, followed her, saying, "She is going to the tomb to weep there."

{32} Then, when Mary came where Jesus was, and saw Him, she fell down at His feet, saying to Him, "Lord, if You had been here, my brother would not have died."

{33} Therefore, when Jesus saw her weeping, and the Jews who came with her weeping, He groaned in the spirit and was troubled. {34} And He said, "Where have you laid him?"

They said to Him, "Lord, come and see."

{35} Jesus wept. {36} Then the Jews said, "See how He loved him!"

{37} And some of them said, "Could not this Man, who opened the eyes of the blind, also have kept this man from dying?"

{38} Then Jesus, again groaning in Himself, came to the tomb. It was a cave, and a stone lay against it. {39} Jesus said, "Take away the stone."

Martha, the sister of him who was dead, said to Him, "Lord, by this time there is a stench, for he has been dead four days."

{40} Jesus said to her, "Did I not say to you that if you would believe you would see the glory of God?" {41} Then they took away the stone from the place where the dead man was lying. And Jesus lifted up His eyes and said, "Father, I thank You that You have heard Me. {42} "And I know that You always hear Me, but because of the people who are standing by I said this, that they may believe that You sent Me." {43} Now when He had said these things, He cried with a loud voice, "Lazarus, come forth!" {44} And he who had died came out bound hand and foot with graveclothes, and his face was wrapped with a cloth. Jesus said to them, "Loose him, and let him go."

{45} Then many of the Jews who had come to Mary, and had seen the things Jesus did, believed in Him. {46} But some of them went away to the Pharisees and told them the things Jesus did.

---

**Outer Aim** Jesus resurrects a man who has been dead for four days.

---

## What the Story Tells Us - Fill in the blanks. The Word Box will help you.

Martha 4	Lazarus glory to God	died Mary	3 Jesus	many would believe sick
-------------	-------------------------	--------------	------------	----------------------------

1. Lazarus was \_\_\_\_\_ and \_\_\_\_\_.
2. \_\_\_\_\_ and \_\_\_\_\_ asked \_\_\_\_\_ to help.
3. Lazarus was in the grave \_\_\_\_\_ days.
4. Jesus raised Lazarus so \_\_\_\_\_ and to give  
\_\_\_\_\_.

## Passages

Job 19:25-27 - For I know that my Redeemer lives, and He shall stand at last on the earth; and after my skin is destroyed, this I know, that in my flesh I shall see God, whom I shall see for myself, and my eyes shall behold, and not another.  
How my heart yearns within me!

Romans 5:19 - For as by one man's disobedience many were made sinners, so also by one Man's obedience many will be made righteous.

John 11:25 - Jesus said to her, "I am the resurrection and the life. He who believes in Me, though he may die, he shall live."

---

**Inner Aim** Jesus, God's Son, has power over death.

---

## What God Tells Us - Fill in the crossword puzzle by using the clues below.

### Across

4. Jesus \_\_\_\_\_ Lazarus from the dead.
5. These people comforted Mary.
7. Friend of Jesus who died.
9. One of the sisters.
10. Shortest verse of the Bible. Jn. 11:35 (2 words)

### Down

1. Lazarus's sister.
2. Lazarus was sick and \_\_\_\_\_.
3. Town where Lazarus lived.
5. \_\_\_\_\_ was a friend of the family.
6. How we talk to God.
8. Jesus \_\_\_\_\_ to help after 2 days.

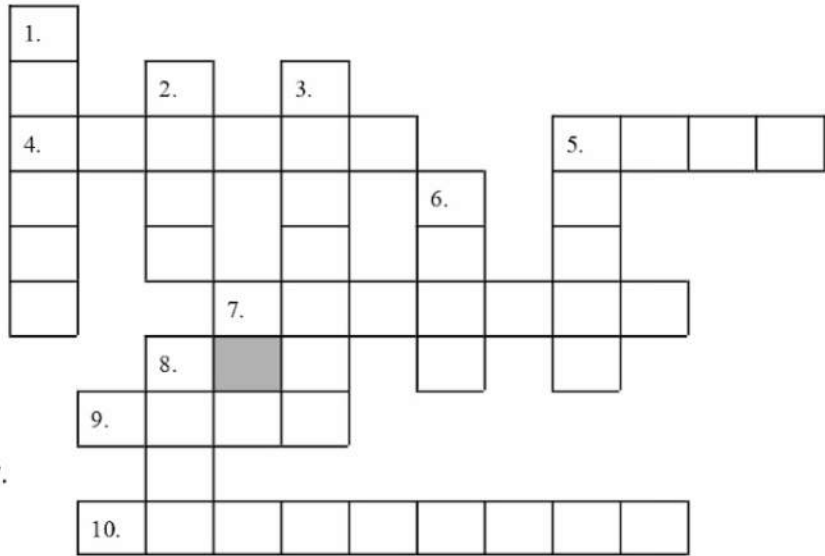

## Hymn - TLH #201 v. 1, 2

Jesus lives! The vict'ry's won!  
 Death no longer can appal me;  
 Jesus lives! Death's reign is done!  
 From the grave Christ will recall me.  
 Brighter scenes will then commence;  
 This shall be my confidence.

Jesus lives! To Him the throne  
 High o'er heav'n and earth is given.  
 I shall go where He is gone,  
 Live and reign with Him in heaven.  
 God is faithful, doubtings, hence!  
 This shall be my confidence.

## Prayer

Dear Lord Jesus,

Through this lesson You call us to believe that You are the Lord of life with power over even death itself. Because of sin within us, we fear death. But You suffered death for us and the punishment of sin that we fear in death. You have taken away the sting of death and replaced it with the assurance that those who believe in You will rise from death to live again, with You, forever. Help us to view death through the eyes of faith in You and Your promises of a joyful resurrection. We ask this, trusting in You as our Lord of Life and Savior. Amen.

# The Parable of the Ten Virgins

Matthew 25:1-13

What do you know about the customs of weddings during Jesus' time and in His country?

They had what we might call a parade going to the wedding and wedding feast. There would be unmarried young women waiting to take the Bridegroom to the wedding.

Let's study this parable Jesus told and find the meaning for our lives.

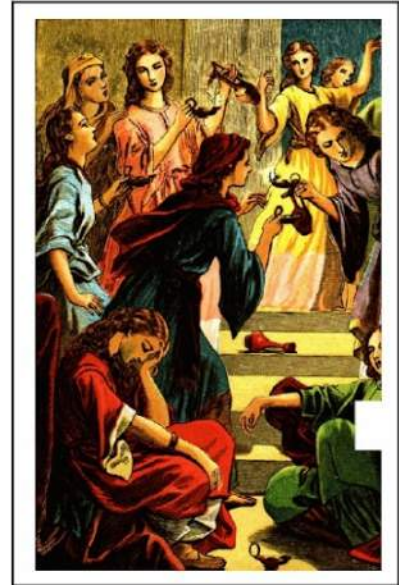

## Prayer

Dear Lord, Help us to study the lesson of the ten virgins today and learn to be prepared for our death. May we be willing listeners and take to heart the lesson of faith. Amen.

## The Story - Matthew 25:1-13

"Then the kingdom of heaven shall be likened to ten virgins who took their lamps and went out to meet the bridegroom. {2} "Now five of them were wise, and five were foolish. {3} "Those who were foolish took their lamps and took no oil with them, {4} "but the wise took oil in their vessels with their lamps. {5} "But while the bridegroom was delayed, they all slumbered and slept.

{6} "And at midnight a cry was heard: 'Behold, the bridegroom is coming; go out to meet him!'

{7} "Then all those virgins arose and trimmed their lamps. {8} "And the foolish said to the wise, 'Give us some of your oil,

for our lamps are going out.'

{9} "But the wise answered, saying, 'No, lest there should not be enough for us and you; but go rather to those who sell, and buy for yourselves.'

{10} "And while they went to buy, the bridegroom came, and those who were ready went in with him to the wedding; and the door was shut.

{11} "Afterward the other virgins came also, saying, 'Lord, Lord, open to us!'

{12} "But he answered and said, 'Assuredly, I say to you, I do not know you.'

{13} "Watch therefore, for you know neither the day nor the hour in which the Son of Man is coming.

---

**Outer Aim - Jesus told a parable or story explaining Judgment Day.**

---



## What the Story Tells Us - True or False

1. \_\_\_\_ When Christ comes He will come at midnight.
2. \_\_\_\_ We will be warned when Christ is coming.
3. \_\_\_\_ Believers are wiser than unbelievers.
4. \_\_\_\_ Those without oil will be damned.
5. \_\_\_\_ Believers are wise and unbelievers are foolish.
6. \_\_\_\_ Be prepared for Christ means we are going about His work.
7. \_\_\_\_ Only women can go to heaven.
8. \_\_\_\_ Parfait has got to be just about the best thing on earth.
9. \_\_\_\_ In this parable Christ is condemning sloth.
10. \_\_\_\_ Everyone who believes is ready for Christ coming.

## What God's Word Tells Us - Discuss the following.

Look at Matthew 7:21 -

"Not everyone who says to Me, 'Lord, Lord,' shall enter the kingdom of heaven,  
but he who does the will of My Father in heaven."

According to this passage who is ready for the coming of Christ?

What is the will of His Father?

Is this Law or Gospel?

Read Matthew 7:22

Many will say to Me in that day, 'Lord, Lord, have we not prophesied in Your name, cast out demons in Your name, and done many wonders in Your name?'

What do the unbelievers claim in an attempt to gain Heaven?

If their claim was valid would they have been received into bliss (compare Matthew 25:34-36 below)?

Then the King will say to those on His right hand, 'Come, you blessed of My Father, inherit the kingdom prepared for you from the foundation of the world: {35} 'for I was hungry and you gave Me food; I was thirsty and you gave Me drink; I was a stranger and you took Me in; {36} 'I was naked and you clothed Me; I was sick and you visited Me; I was in prison and you came to Me.'

Since this passage so clearly portrays the Law as the key to heaven how does it fit with the passage "For it is by grace you have been saved, through faith--and this not from yourselves, it is the gift of God-- not by works, so that no one can boast" (Ephesians 2:8-9) ( be sure to look at the context of the passages)?

Who then is truly prepared for the Coming of our Lord?

---

**Inner Aim - When we die our soul will go to heaven to be with Jesus.**

---



## Passages

Matthew 24:44 - Therefore you also be ready, for the Son of Man is coming at an hour you do not expect.

Matthew 26:41 "Watch and pray, lest you enter into temptation. The spirit indeed is willing, but the flesh is weak."

Matthew 24:42 - Watch therefore, for you do not know what hour your Lord is coming.

## Hymn - TLH #609 v. 1, 3

"Wake, awake, for night is flying,"  
The watchmen on the heights are crying;  
"Awake, Jerusalem, arise!"  
Midnight hears the welcome voices  
And at the thrilling cry rejoices:  
"Oh, where are ye, ye virgins wise?  
The Bridegroom comes, awake!  
Your lamps with gladness take! Hallelujah!  
With bridal care yourselves prepare  
To meet the Bridegroom, who is near."

Now let all the heav'ns adore Thee,  
Let men and angels sing before Thee,  
With harp and cymbal's clearest tone.  
Of one pearl each shining portal,  
Where, dwelling with the choir immortal,  
We gather round Thy radiant throne.  
No vision ever brought,  
No ear hath ever caught, such great glory;  
Therefore will we eternally  
Sing hymns of praise and joy to Thee. Amen

## Prayer

Dear Heavenly Father,  
Thank You for sending Jesus to live a perfect life and to die for our sins on the cross.  
Thank You also for sending the Holy Spirit into our hearts to give us faith. Please keep that lamp of faith full of oil from Your Word so that we are ready to meet You. In Jesus' Name we pray. Amen.